

MONOGRAPHY



006 LIVING

007 ALAYA ASIX sofa
013 ALAYA central table
012 ALAYA console
011 ALAYA courtesy table
020 ALAYA modular sofa
026 ALAYA side element low corner
027 ALAYA side element high dormeuse
031 ALLURE central table
055 ALLURE side table
022 ANTIBES central table marble top
087 ANTIBES central table
025 ARAMIS armchair
037 ATRIUM modular sofa
051 ATRIUM sofa

083 COLINE sofa

059 GALA desk

045 JEAN armchair

075 LOUISE sofa

033 MEZZALUNA console
041 MONTREAL backsofa console
057 MONTREAL bookshelf
056 MONTREAL console

069 NUAGE tv cabinet

042 PETITE side table

071 REFLECT mirror

047 SEGMENTI wall decoration
088 SOL side table
088 SOL sofa table
089 SOL sofa table composition

081 TRUFFLE sofa table
015 TWILLY armchair

061 VAGUE armchair
065 VAGUE sofa

092 DINING

107 ANTIBES table base, DOMINO table top

120 CARTESIO table base, ORIGAMI table top

124 CARTESIO table base, MIKADO table top

128 CLAIRE chair

117 HYDE PARK wall decoration

110 MAXIME chair

099 MAXIME SOFT chair

115 MEMORIES display cabinet

103 MEZZALUNA table base, ORIGAMI table top

097 MEZZALUNA table base, SEGMENTI table top

112 NUAGE sideboard

104 TWILLY chair

092 TWILLY chair with arms

132 SLEEPING

147 ALLURE mirror

137 ANTIBES chest of drawers

137 ANTIBES night table

139 ASTORIA bed

153 CHELSEA bed

143 HYDE PARK bed

156 MAGIC chest of drawers

161 MAGIC dressing

162 MAGIC highboy

159 MAGIC night table

169 NOMAD rug

133 SOHO bed

166 TAMBOUR rug

WELCOME TO THE SENSUAL HOME OF MONOGRAPHY,
WHICH CONVEYS AN UNUSUAL TYPE OF BEAUTY,
DEEPLY REFINED AND ELEGANTLY SEDUCTIVE. A UNIVERSE
WHERE RATIONALISTIC AESTHETICS MELD WITH TIMELESS
DESIGN INSPIRATIONS, THANKS TO ALCHEMICAL
PROPORTIONS AND UNUSUAL MATERIALITY.



THE LIVING AREA OF MONOGRAPHY EPITOMIZES CONTEMPORARY SOPHISTICATION AND SUBTLE REFINEMENT IN EVERY PIECE OF FURNITURE. CLEAN LINES, EXQUISITE MATERIALS BECOME THE HALLMARK OF MINIMALIST DESIGN: A LIBERATED AESTHETIC THAT ALLOWS MONOGRAPHY PIECES TO SEAMLESSLY INTEGRATE INTO THE MOST DIVERSE ENVIRONMENTS. LET'S EXPLORE THE SPACES WE INHABIT AND CREATE REFINED FURNISHINGS TO MAKE THEM TRULY UNIQUE.

Technical info → P.172

ALAYA ASIX 4 SEATS, ALAYA COURTESY TABLE, ALAYA CENTRAL TABLE, JEAN ARMCHAIR, TWILLY ARMCHAIR, TAMBOUR RUG





ALAYA ASIX 4 SEATS, ALAYA COURTESY TABLE



ALAYA COURTESY TABLE



ALAYA CONSOLLE



ALAYA CENTRAL TABLE





ALAYA COURTESY TABLE



ALAYA CONSOLLE



TWILLY ARMCHAIR

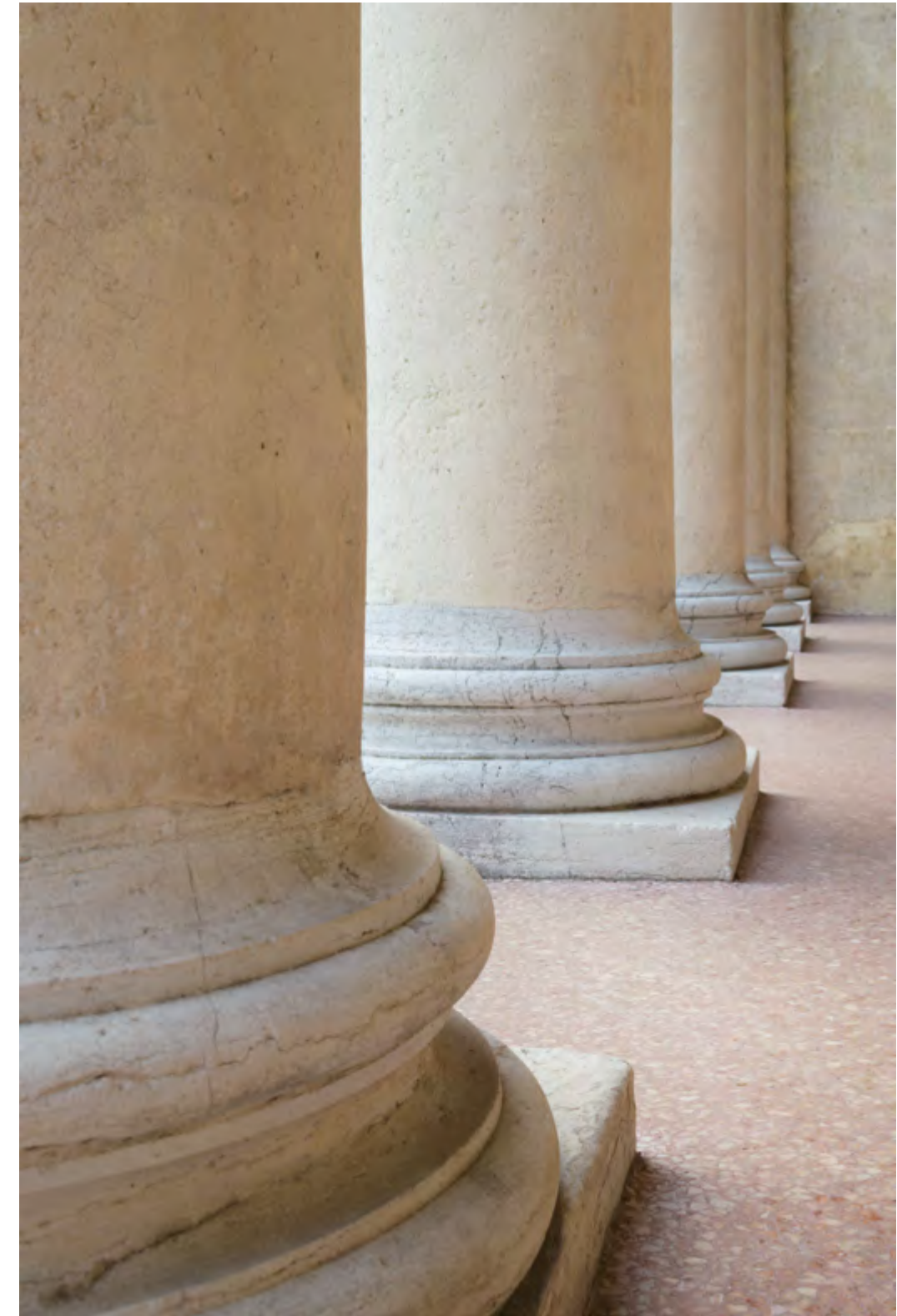





ANTIBES CENTRAL TABLE LARGE, ANTIBES CENTRAL TABLE SMALL



ALAYA MODULAR SOFA, ANTIBES CENTRAL TABLE LARGE



ARAMIS ARMCHAIR

ALAYA SIDE ELEMENT LOW CORNER, ALAYA SIDE ELEMENT HIGH DORMEUSE, ALLURE CENTRAL TABLE CIRCULAR, ALLURE SIDE TABLE





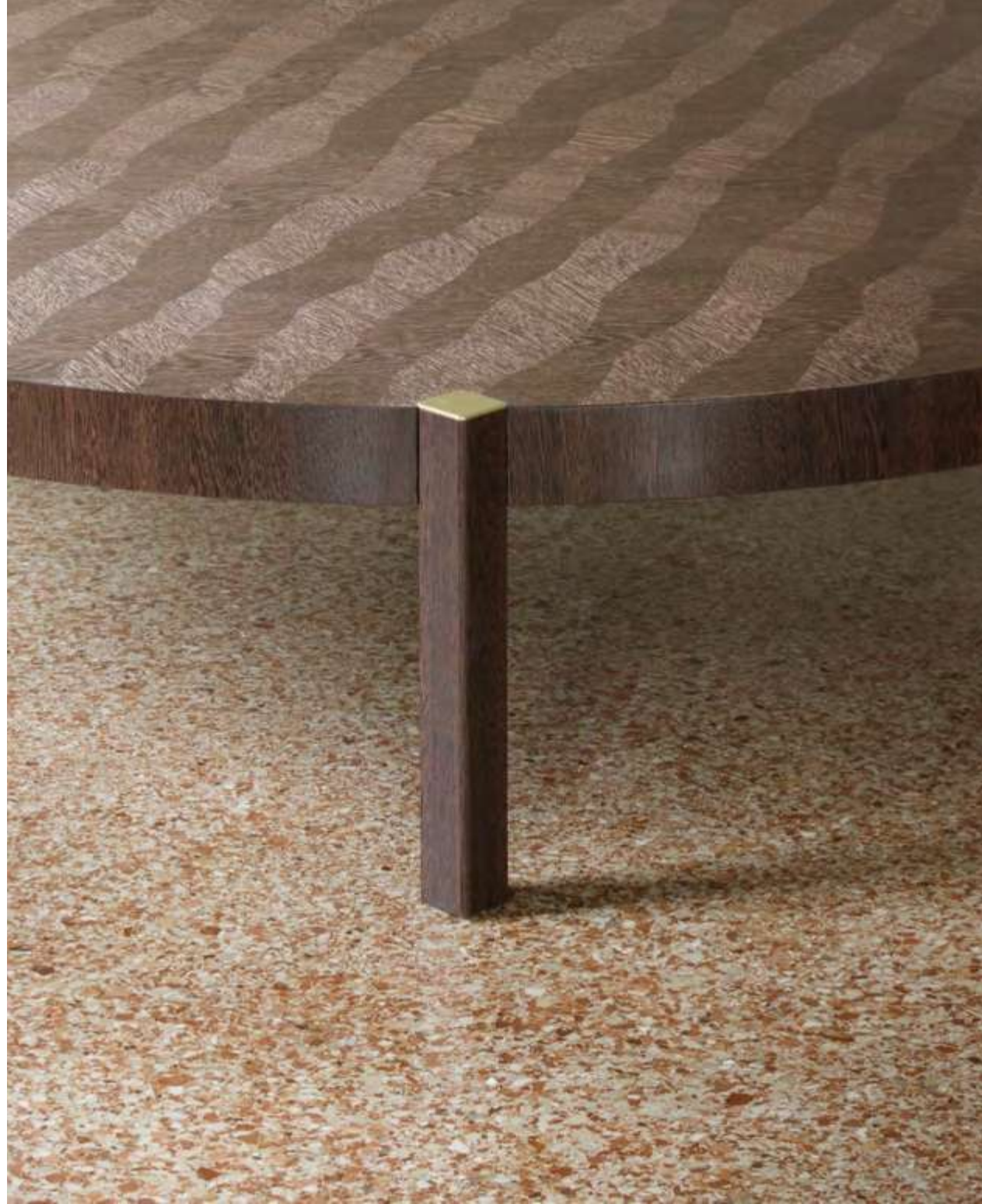

ALLURE CENTRAL TABLE CIRCULAR



MEZZALUNA CONSOLLE

EXPERIENTIAL VOLUMES MERGE WITH STYLISTIC FUNCTIONALITY. THESE ARE THE DISTINCTIVE TRAITS OF THE NEW MONOGRAPHY FURNISHINGS. UNIQUE PIECES CHARACTERIZED BY THE DISTINCTIVE TRAITS OF MINIMALIST AND TIMELESS ELEGANCE: THE IDEAL PRODUCTS TO ENRICH LIVING SPACES WITH AN UNEXPECTED TOUCH OF MODERNISM.



ATRIUM MODULAR SOFA, PETITE SIDE TABLE, ANTIBES CENTRAL TABLE SMALL





ATRIUM MODULAR SOFA

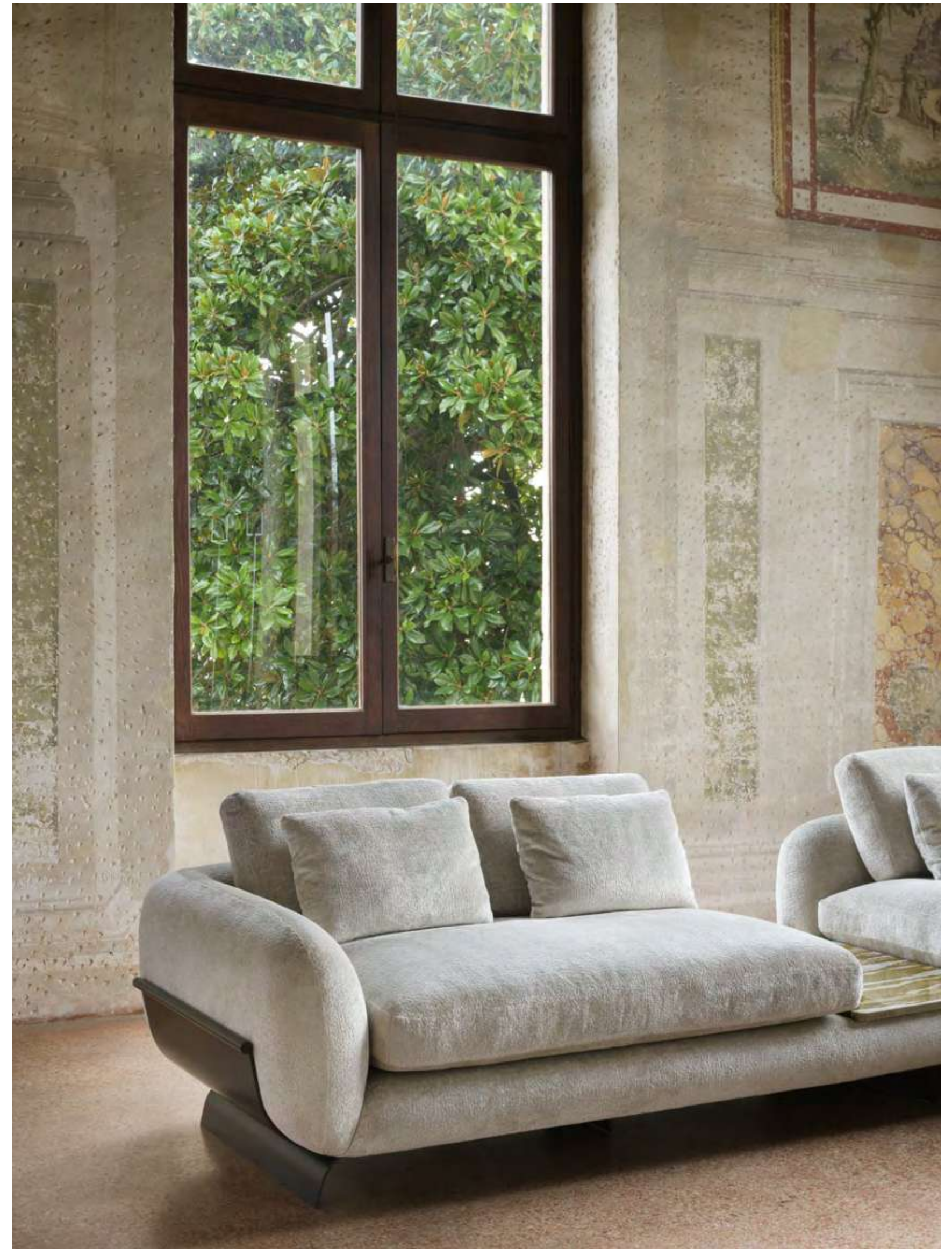



MONTREAL BACKSOFA CONSOLLE





PETITE SIDE TABLE



JEAN ARMCHAIR





SEGMENTI WALL DECORATION RECTANGULAR ELEMENTS





ATRIUM SOFA 4 SEATS







ALLURE SIDE TABLE





GALA DESK, TWILLY CHAIR

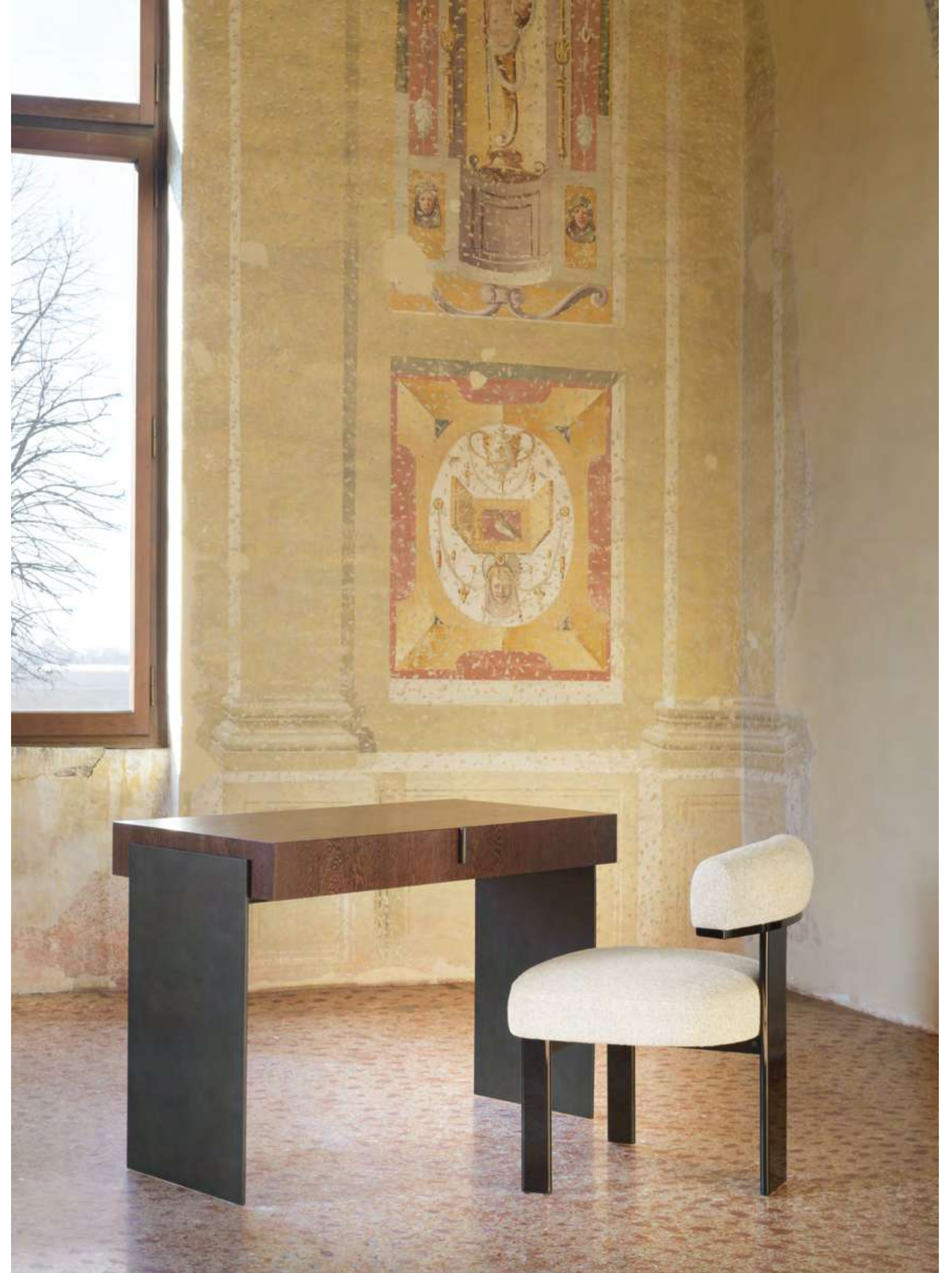



VAGUE ARMCHAIR







VAGUE ARMCHAIR



NUJAGE TV CABINET



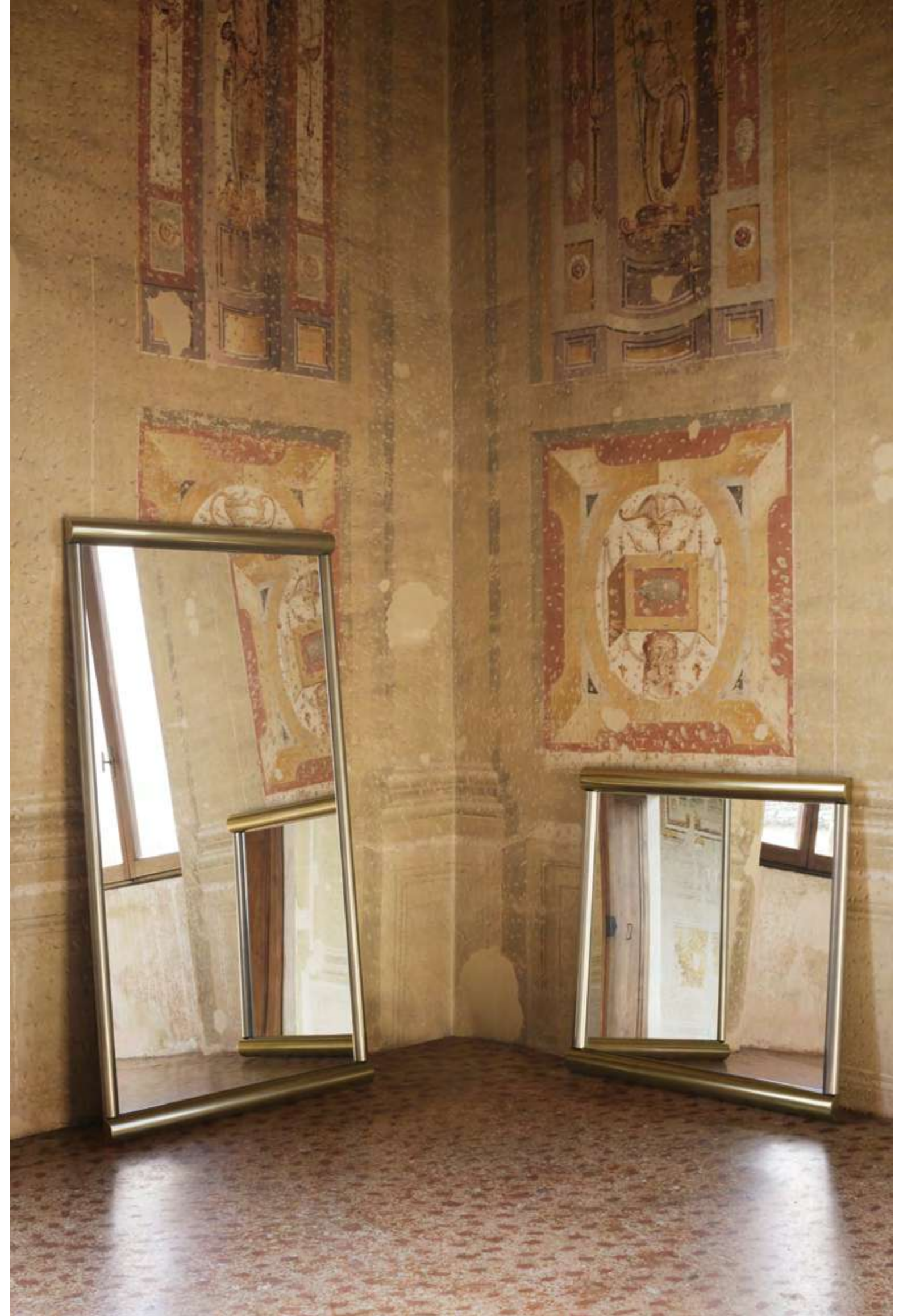

REFLECT RECTANGULAR MIRROR, REFLECT SQUARE MIRROR

THE COMMITMENT TO EXCELLENCE IS AT THE HEART OF OUR PRODUCTION, EMBODIED BY UNIQUE, HANDMADE FURNISHINGS. DELVE INTO THE UNIVERSE OF MONOGRAPHY TO DISCOVER A WIDE SELECTION OF FINE FURNITURE CRAFTED WITH CARE AND DEDICATION. EACH PIECE IS A WORK OF ART THAT EXUDES A SENSE OF PRIVATE LUXURY AND SOPHISTICATION.



LOUISE SOFA 4 SEATS, TRUFFLE 120 SOFA TABLE, TRUFFLE 45 SOFA TABLE, ARAMIS ARMCHAIR, TAMBOUR RUG





LOUISE SOFA 4 SEATS

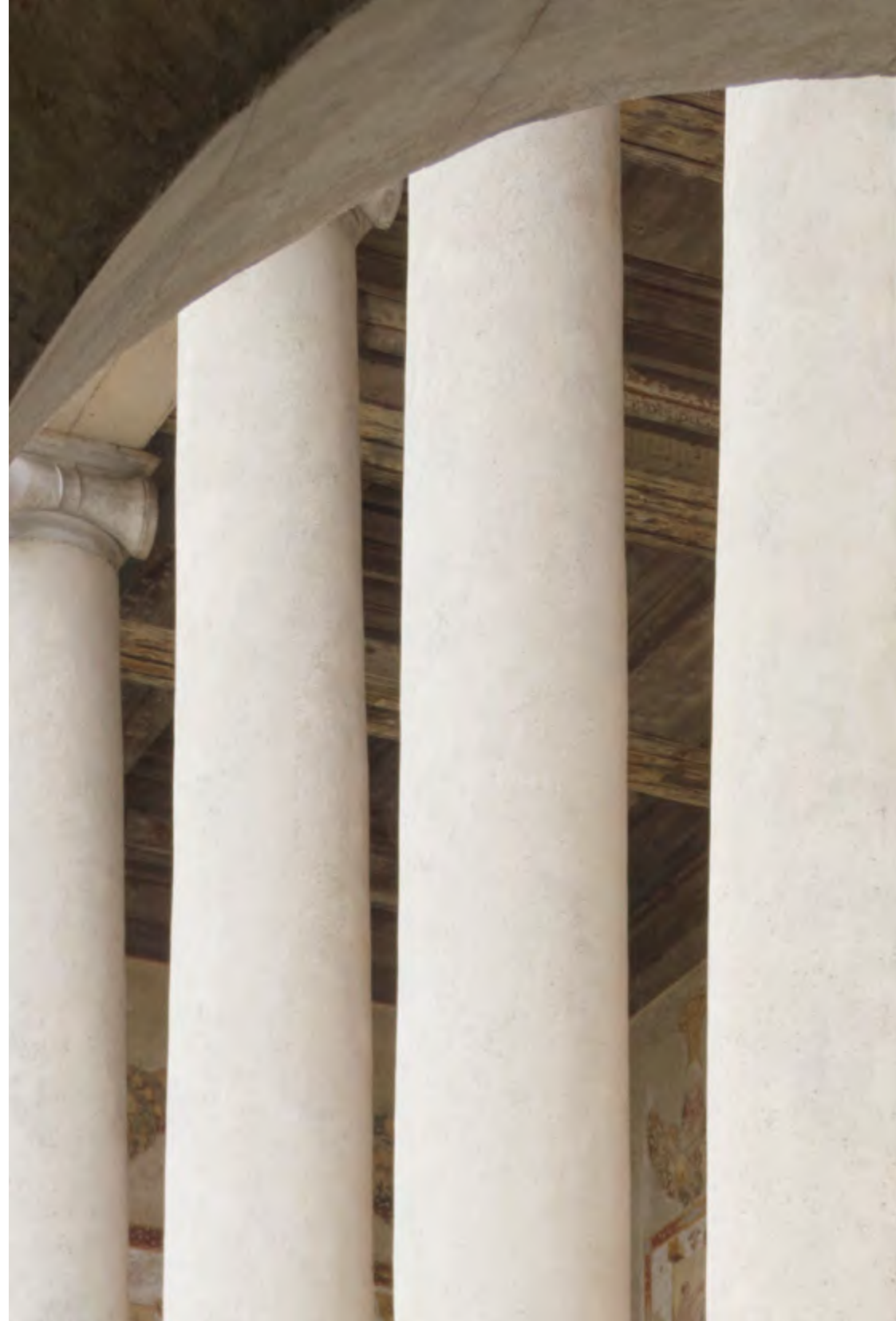

TRUFFLE 120 SOFA TABLE, ARAMIS ARMCHAIR, TAMBOUR RUG



TRUFFLE 120 SOFA TABLE, TRUFFLE 80 SOFA TABLE, TRUFFLE 45 SOFA TABLE

COLINE SOFA 4 SEATS, VAGUE ARMCHAIR, ANTIBES CENTRAL TABLE LARGE, ANTIBES CENTRAL TABLE SMALL, TAMBOUR RUG





SENSUAL HOME

COLINE SOFA 4 SEATS



ANTIBES CENTRAL TABLE SMALL

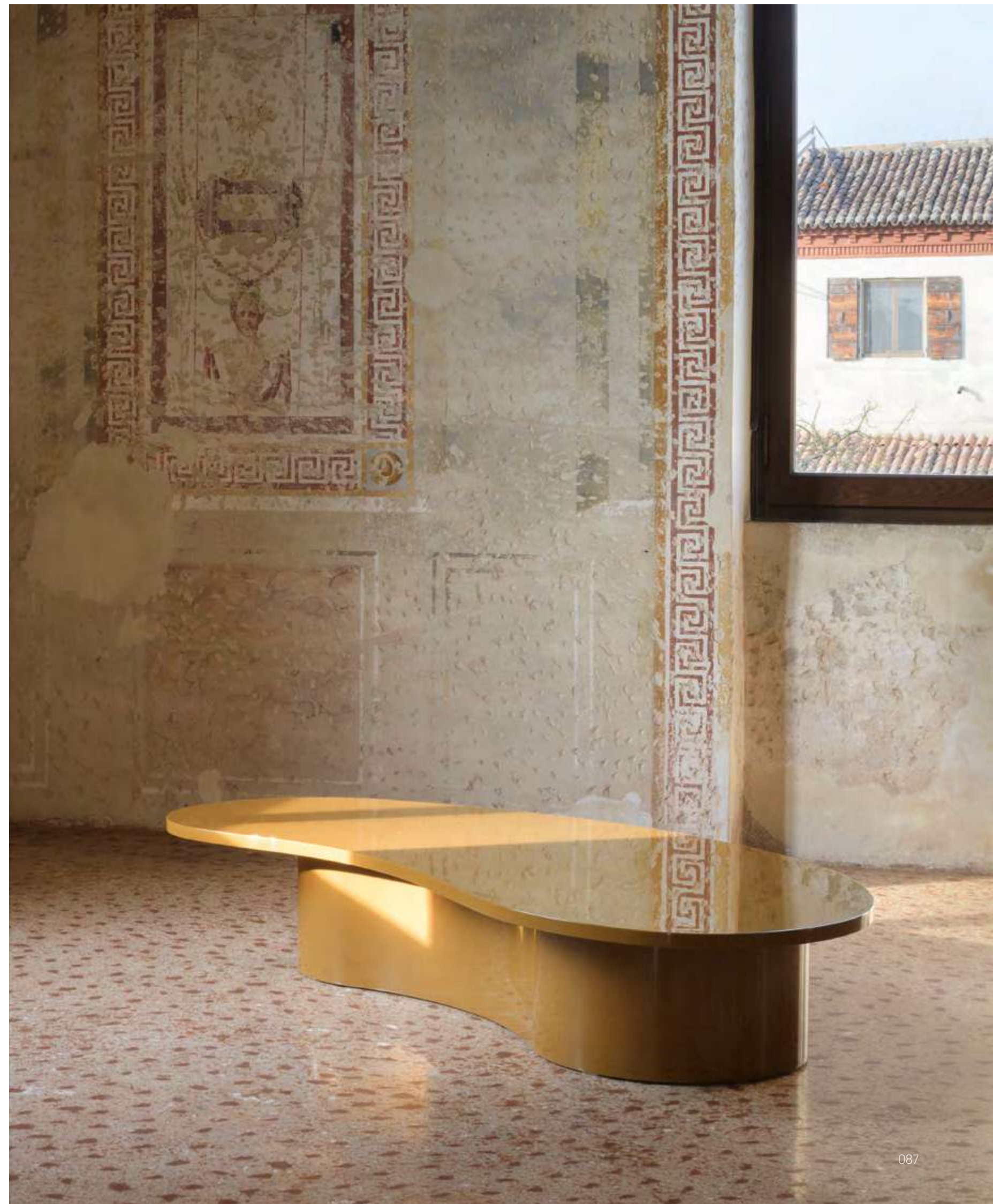

ANTIBES CENTRAL TABLE LARGE



SOL SIDE TABLE, SOL SOFA TABLE



VAGUE ARMCHAIR, SOL SOFA TABLE COMPOSITION

RELYING ON A VISION OF ETERNAL ELEGANCE AND RATIONALISM, MONOGRAPHY SHAPES MATERIALS TO ENHANCE THEIR QUALITIES, CREATING FURNISHINGS THAT ARE AESTHETICALLY PLEASING AS WELL AS FUNCTIONAL OVER TIME. OUR FOCUS ON THE EMOTIONAL ALCHEMY OF DESIGN IS REFLECTED IN THE METICULOUS SEARCH FOR PREMIUM MATERIALS.



TWILLY CHAIR WITH ARMS

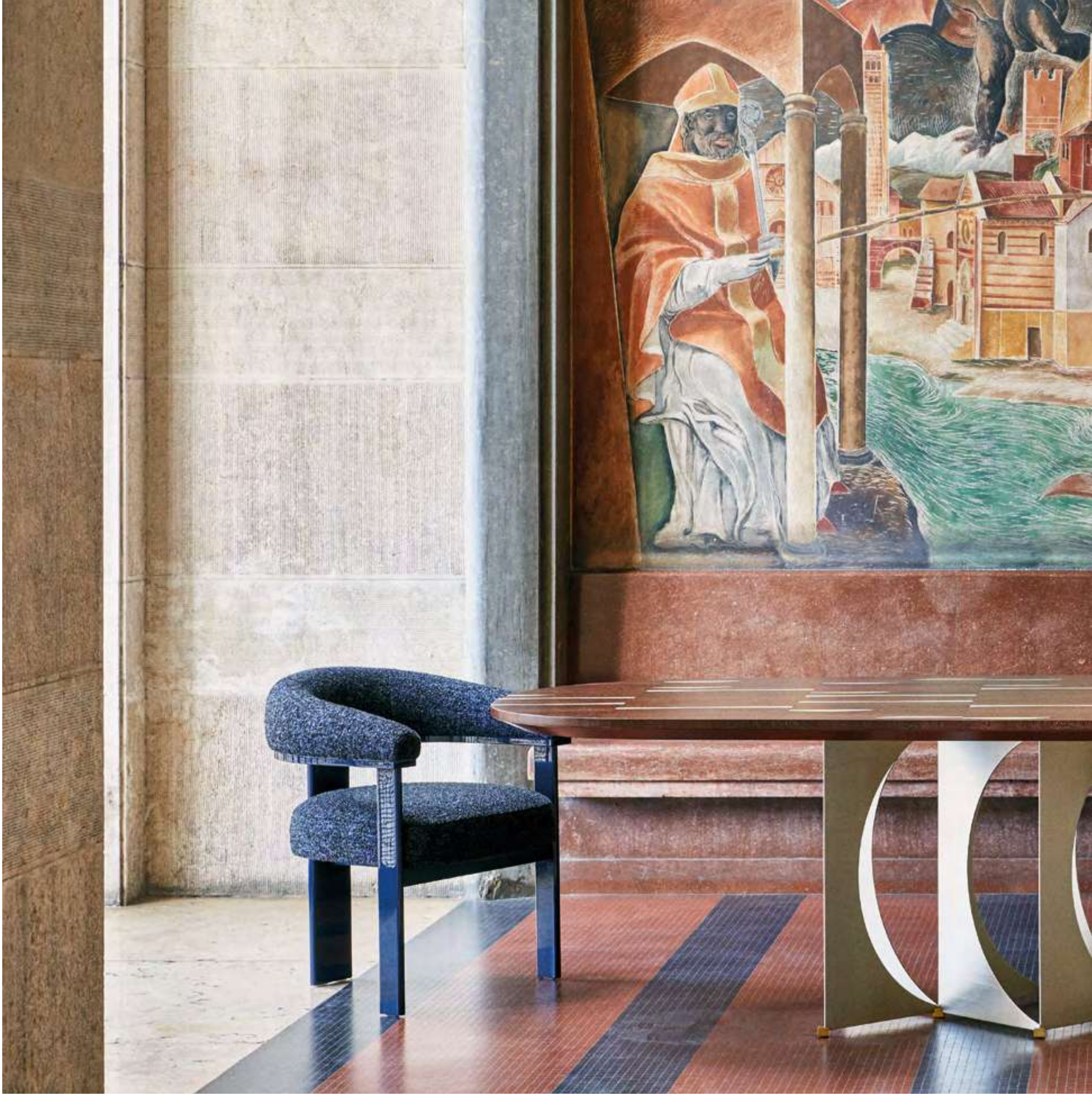

SEGMENTI OVAL TOP





TWILLY CHAIR WITH ARMS



MEZZALUNA BASE FOR OVAL TOP, SEGMENTI TOP FOR OVAL TABLE 300, MAXIME SOFT CHAIR



EACH MONOGRAPHY PIECE FOR THE DINING AREA REFLECTS A CONTEMPORARY ELEGANCE THAT FOSTERS A CONVIVIAL ATMOSPHERE. THE SOPHISTICATION OF THE FORMS MERGES WITH THE SELECTION OF REFINED MATERIALS TO CREATE AN EMOTION OF HARMONIOUS COHERENCE. ELEGANTLY ESSENTIAL, MONOGRAPHY PIECES ARE DESIGNED TO BE LIVED EVERY DAY AND TO BE ADMIRERD.

Technical info → P.172



MAXIME SOFT CHAIR





MAXIME SOFT CHAIR







TWILLY CHAIR







DOMINO TOP FOR ROUND TABLE 160



MAXIME CHAIR



MAXIME CHAIR



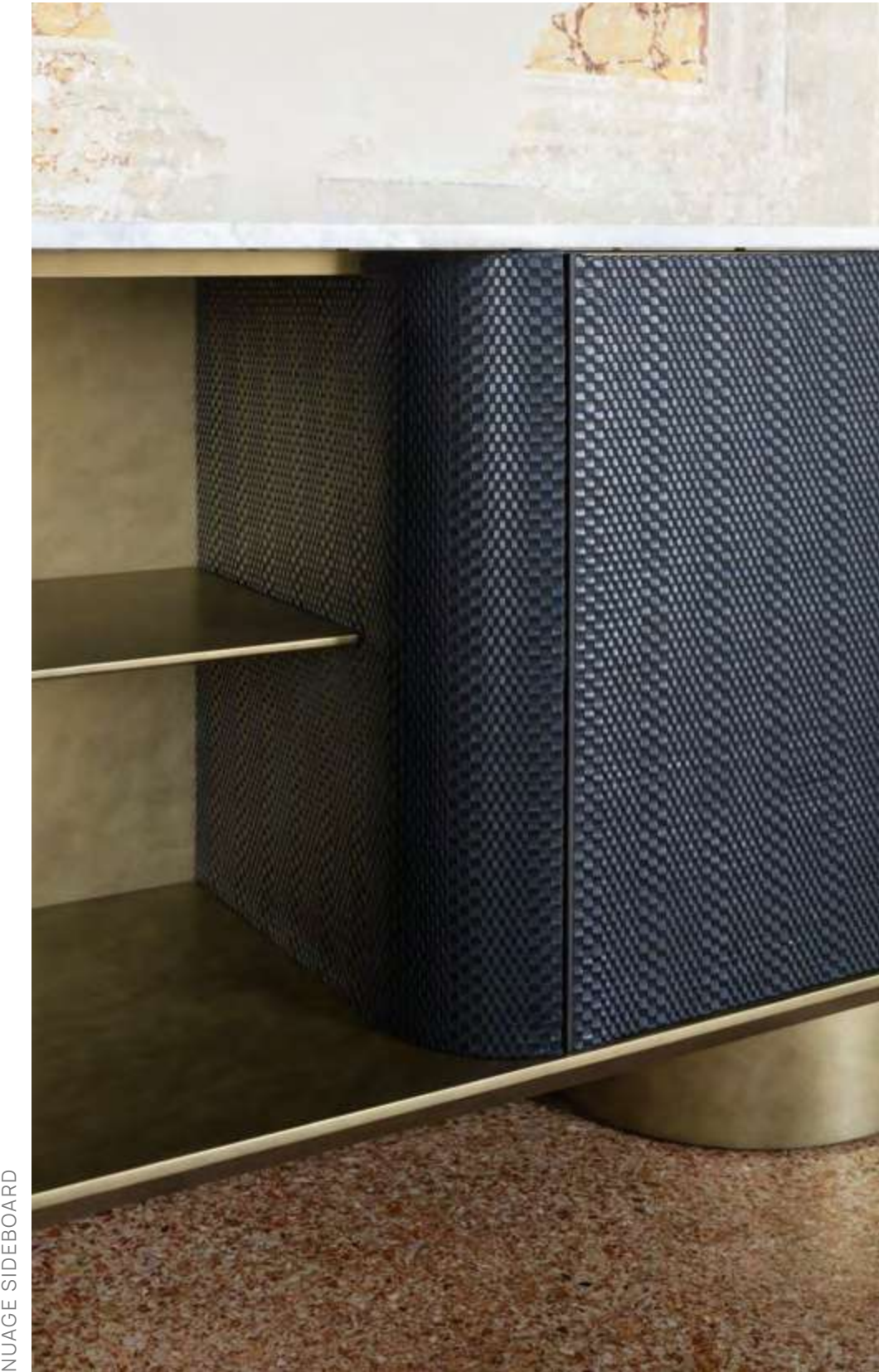

NUAGE SIDEBOARD

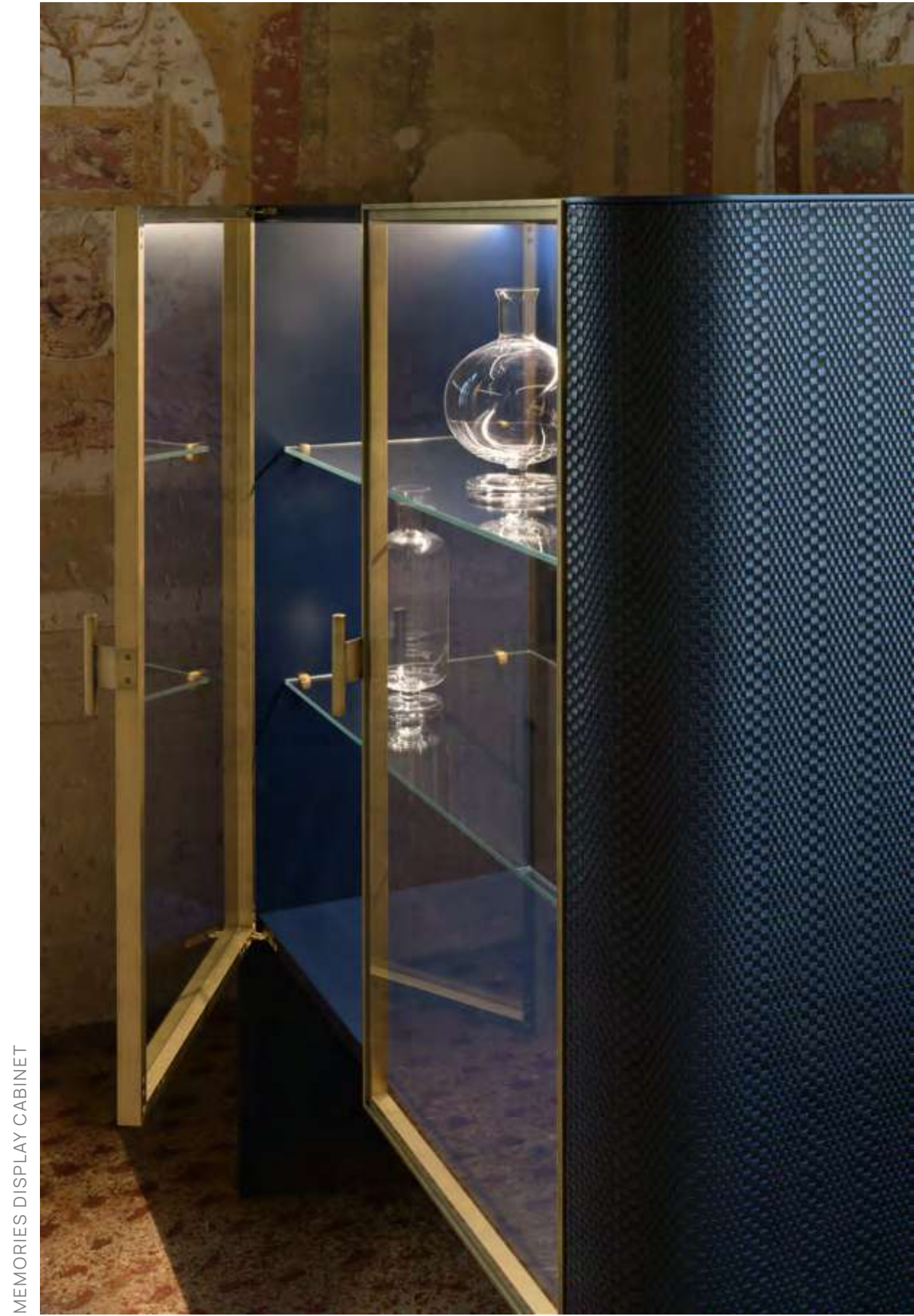

MEMORIES DISPLAY CABINET

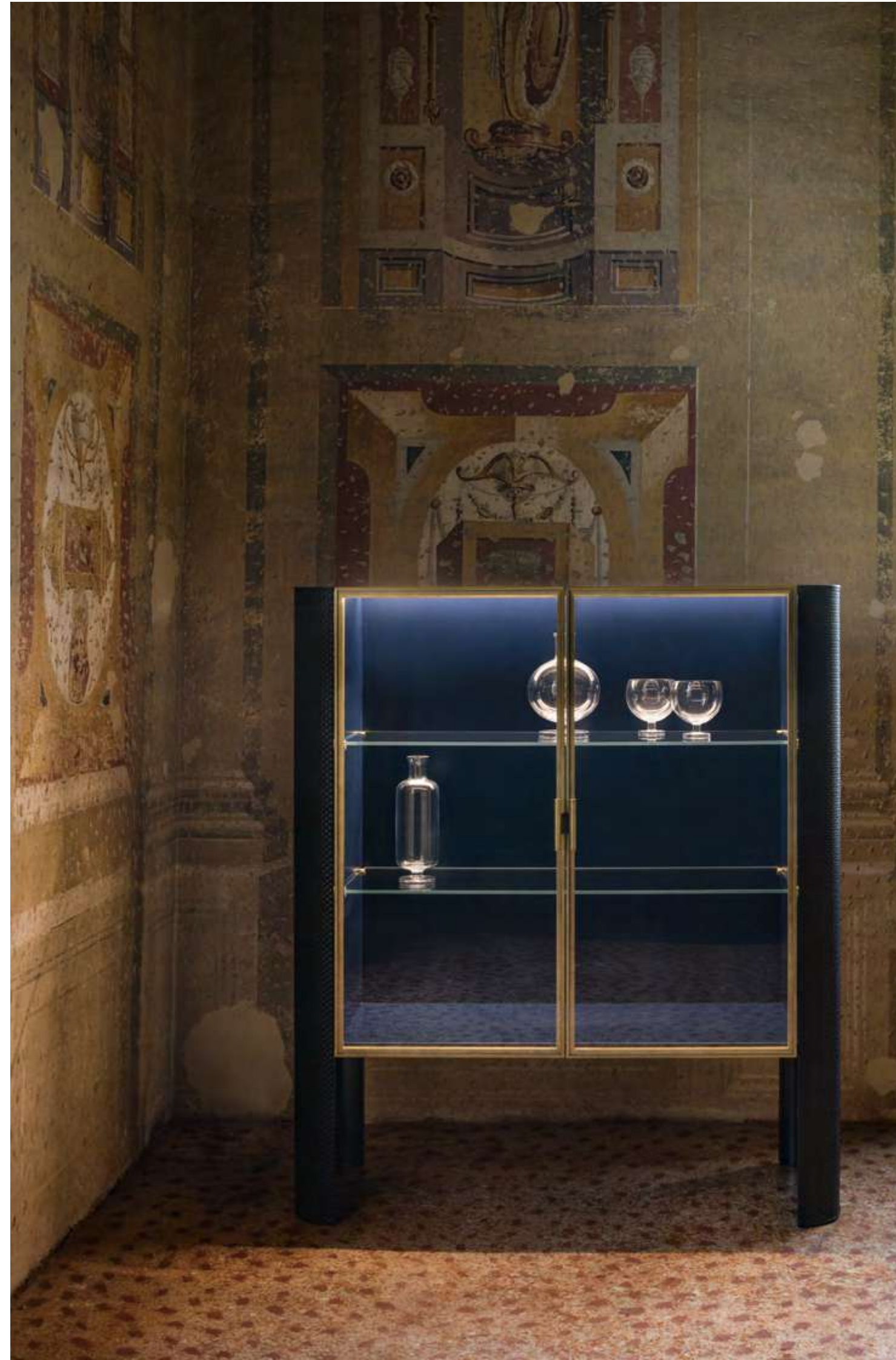



HIDE PARK WALL DECORATION

THE EMBODIMENT OF TIMELESS BEAUTY REFLECTS AN IMPRINT THAT COMMUNICATES REFINED CONTEMPORANEITY. OUR PIECES ARE ELEGANTLY SIMPLE AND DESIGNED TO CREATE AN ATMOSPHERE OF EVERYDAY SOPHISTICATION. OUR COLLECTION INCLUDES ESSENTIAL ELEMENTS OF INTERIOR DESIGN, INTENDED TO FURNISH BOTH HOME AND OFFICE SPACES WITH FUNCTIONALITY AND STYLE.







CARTESIO BASE FOR OVAL TOP, ORIGAMI OVAL TOP







MIKADO ROUND TOP



CLAIRE CHAIR



A SENSE OF REFINED LUXURY IS PORTRAYED THROUGH THE CREATION OF AN ATMOSPHERE THAT COMBINES FUNCTIONALITY WITH THE HARMONY OF STYLE. THE LINES AND SHAPES OF THE NEW MONOGRAPHY COLLECTION REFLECT A SOFT AND ENVELOPING VISION OF CURRENT DESIGN, CAPABLE OF BESTOWING A TOUCH OF CONTEMPORARY SENSUALITY TO ANY SPACE.





FOR MONOGRAPHY, THE SLEEPING AREA IS THE REPRESENTATION OF AN EMOTIONAL ALCHEMY, GIVING LIFE TO UNIQUE FURNISHINGS THAT CONVEY RELAXING SENSATIONS AND CREATE ETHEREAL ATMOSPHERES. THE REFLECTION OF A PERSONAL LIFESTYLE THROUGH REFINED DESIGN RIGOR AND PRODUCTION EXCELLENCE. AS IN A DREAM WORKSHOP, THE PRODUCTS EVOKE NOSTALGIA AND ROMANTICISM, EXPERIMENTING WITH MATERIALS, TECHNIQUES, AND FABRICS TO OUTLINE THE MOST SEDUCTIVE IDEAS.

Technical info → P.172



ANTIBES NIGHT TABLE



SOHO BED



ASTORIA BED QUEEN SIZE, ANTIBES NIGHT TABLE, TWILLY ARMCHAIR





ANTIBES CHEST OF DRAWERS

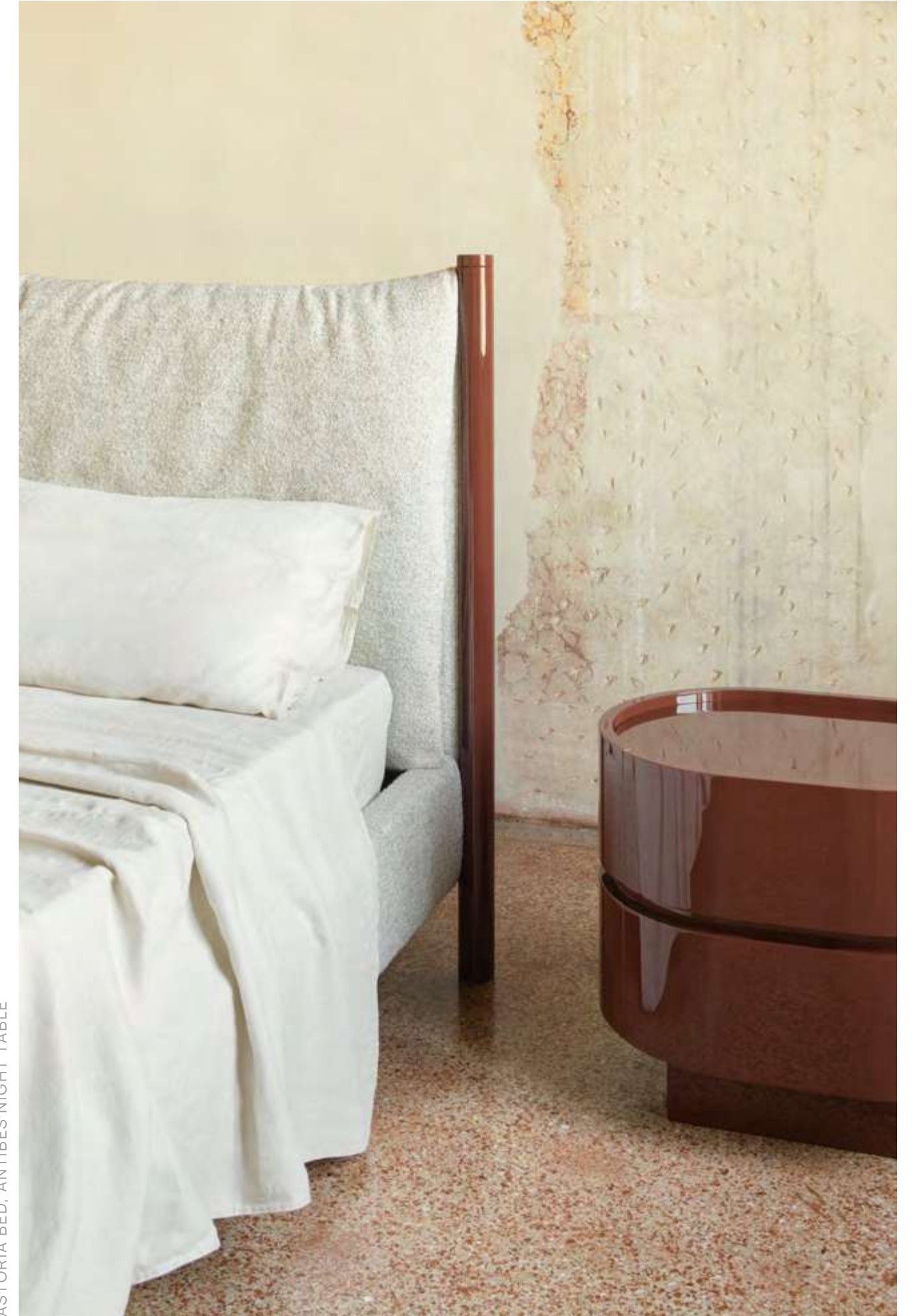

ASTORIA BED, ANTIBES NIGHT TABLE

HYDE PARK BED QUEEN SIZE, ANTIBES NIGHT TABLE





HYDE PARK BED



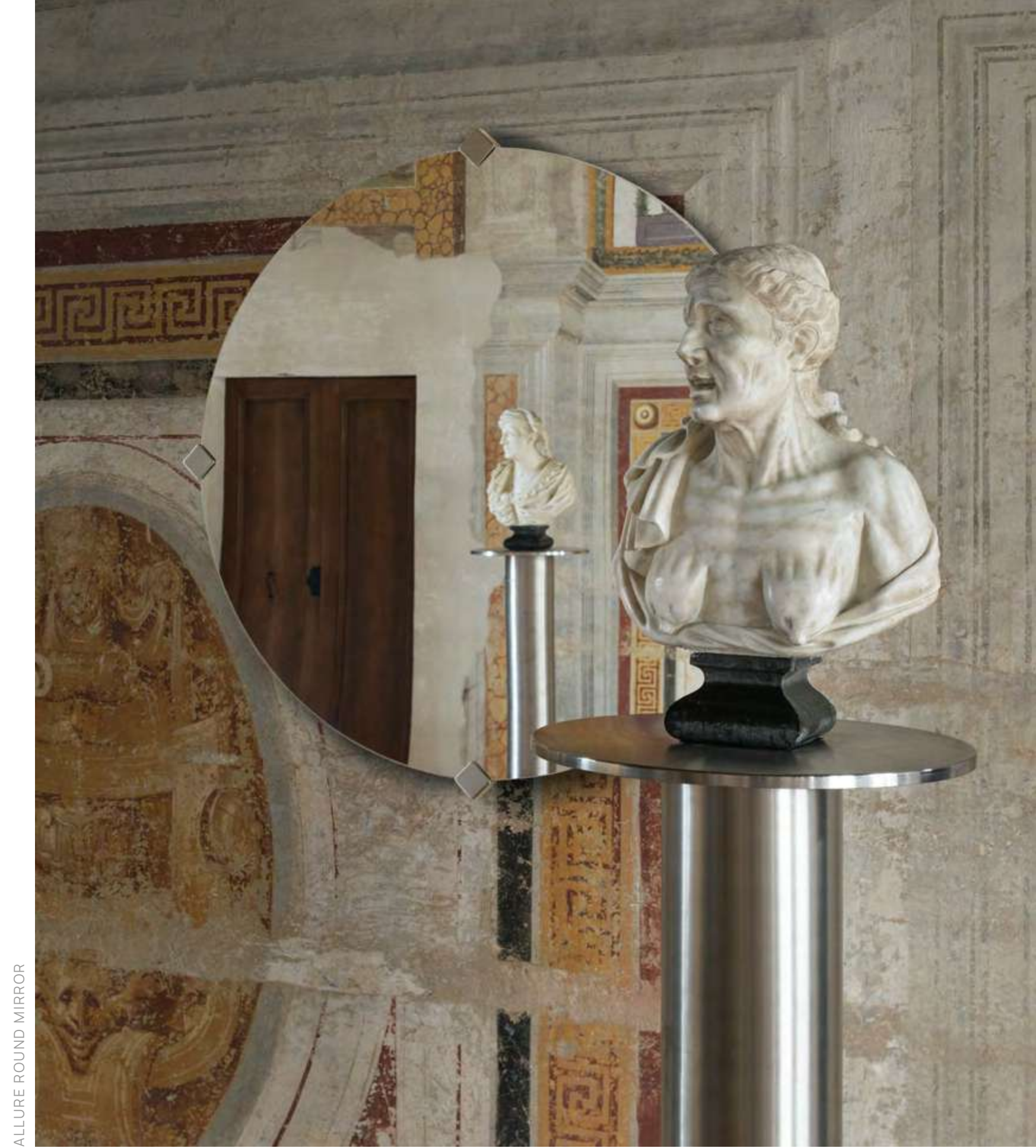

ALLURE ROUND MIRROR



ANTIBES NIGHT TABLE



ANTIBES CHEST OF DRAWERS

EXPRESSING AN ECLECTIC APPROACH, THE MONOGRAPHY COLLECTION OFFERS A WIDE SELECTION OF METICULOUSLY CRAFTED FURNITURE, AIMED AT COMPLEMENTING SLEEPING SPACES WITH AN UNUSUAL TYPE OF BEAUTY. THE TIMELESS AESTHETIC OF OUR FURNISHINGS AND MASTERFUL WORKMANSHIP OF MATERIALS ARE THE TRUE SECRET TO AN ELEGANT LIVING SENSATION.

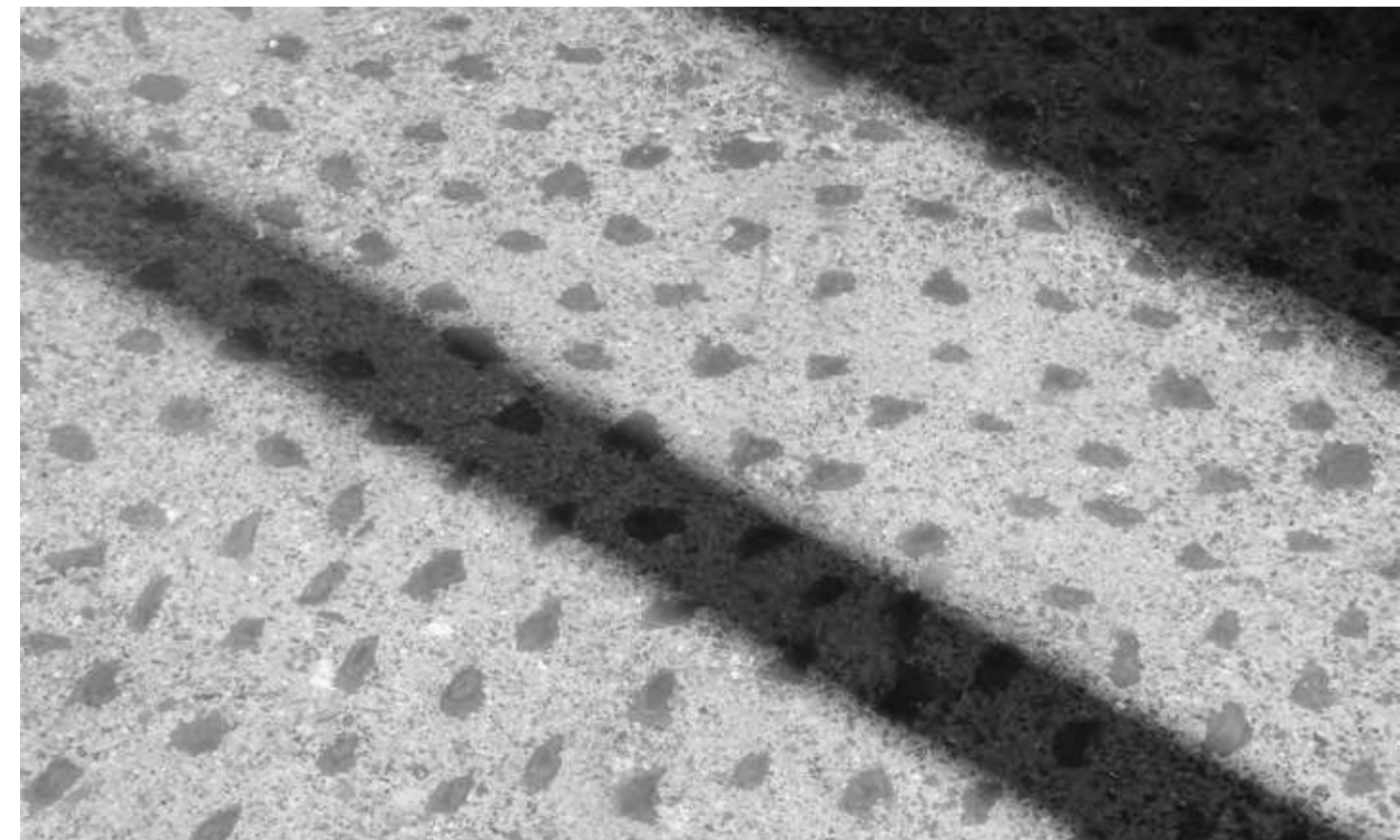

CHELSEA BED QUEEN SIZE, MAGIC NIGHT TABLE, MAGIC CHEST OF DRAWERS







MAGIC NIGHT TABLE, MAGIC CHEST OF DRAWERS



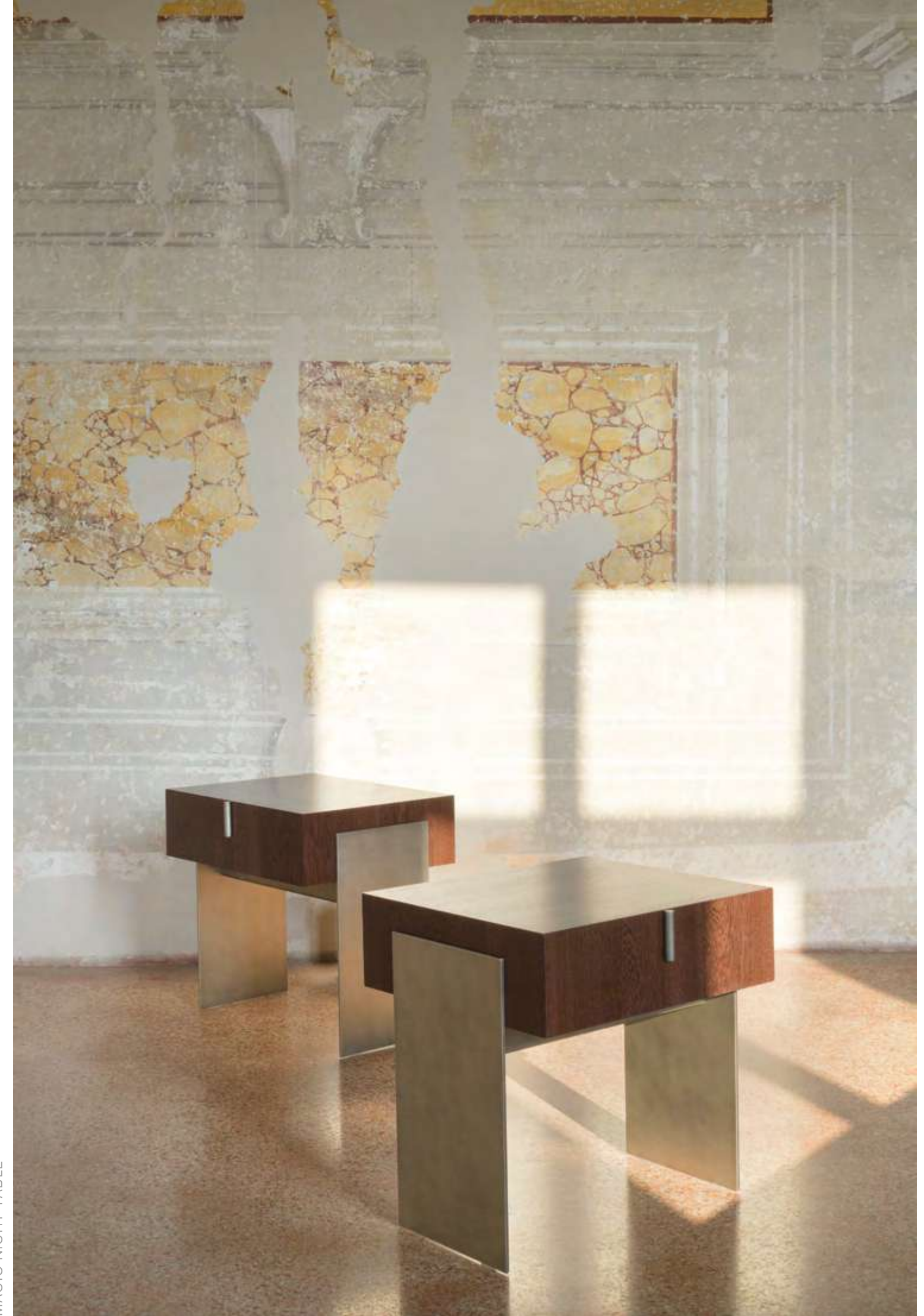

MAGIC NIGHT TABLE

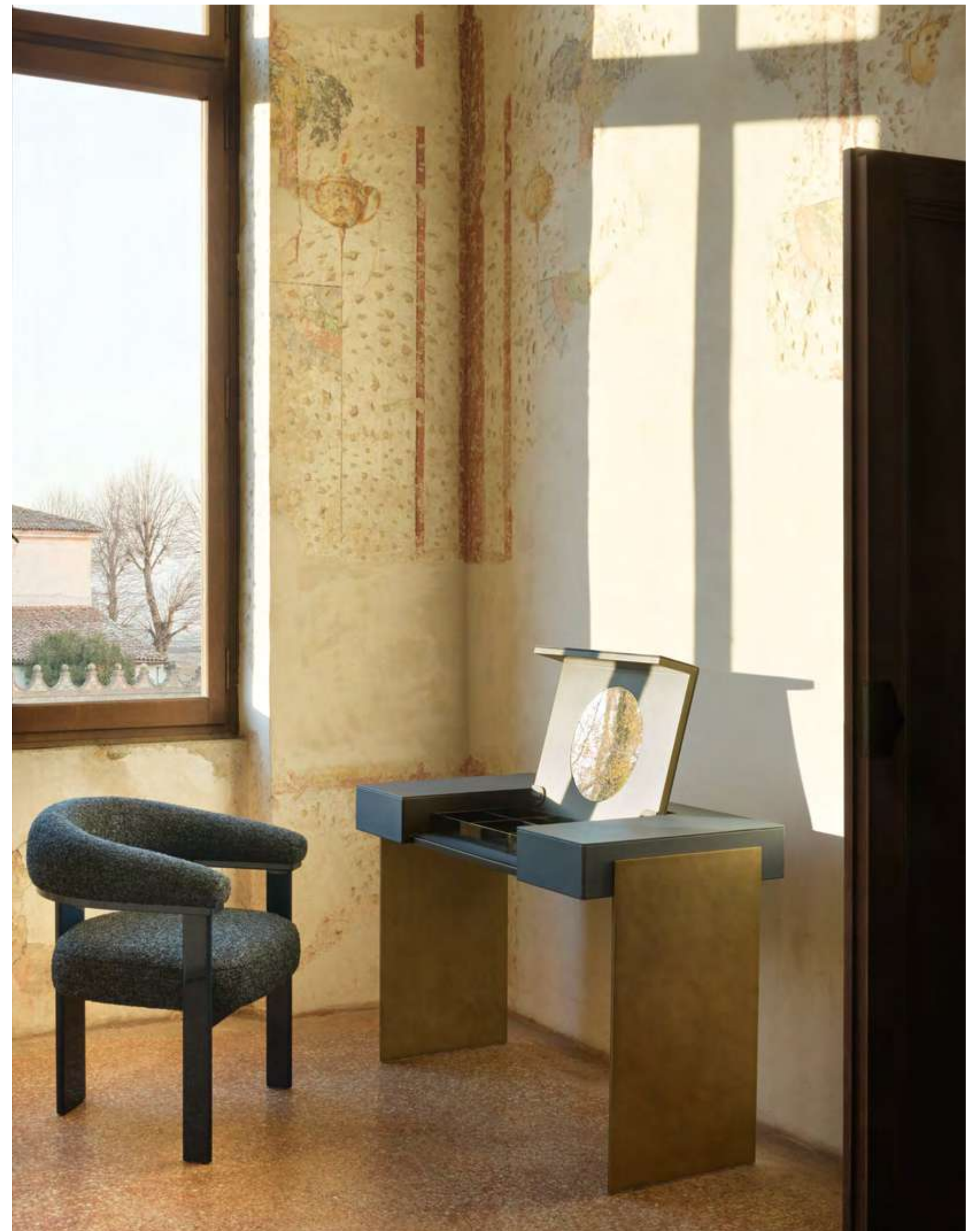
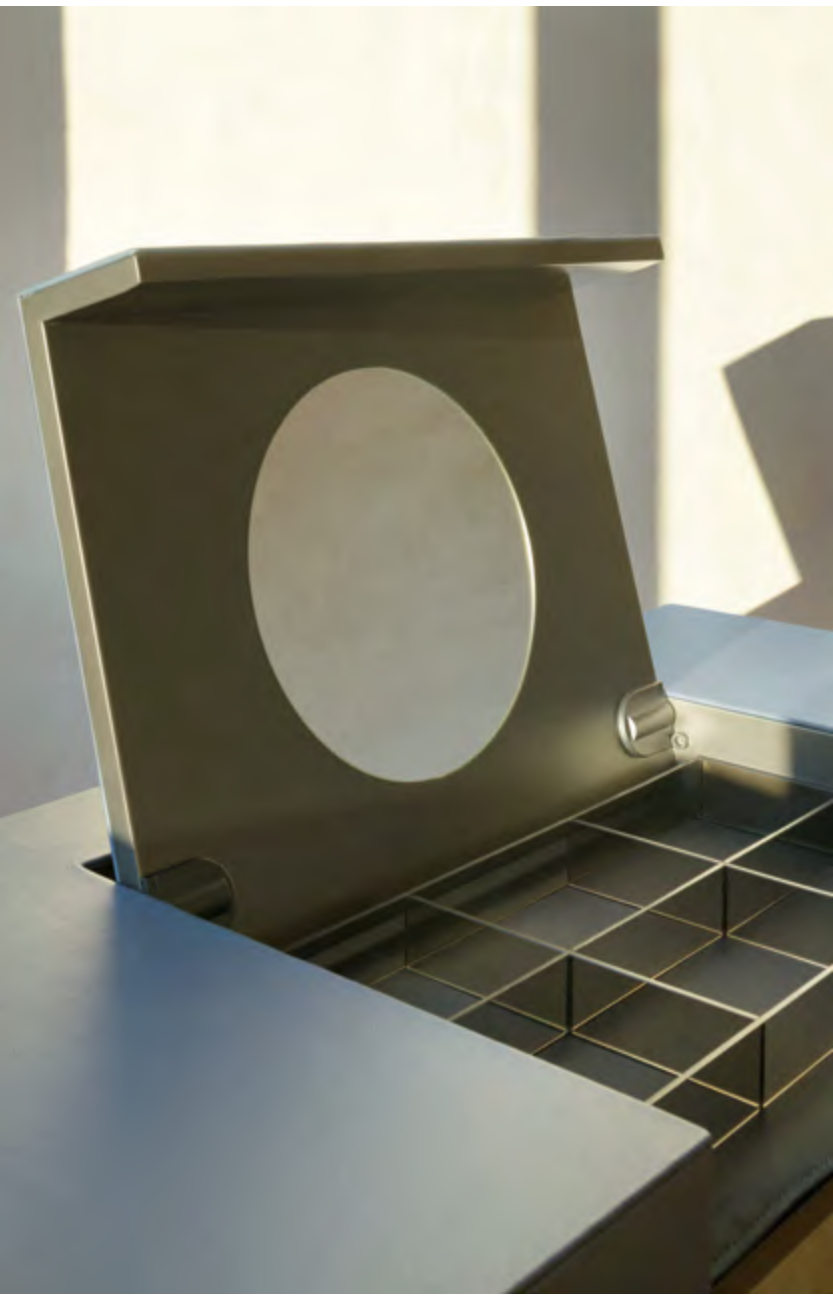

MAGIC DRESSING, TWILLY CHAIR WITH ARMS

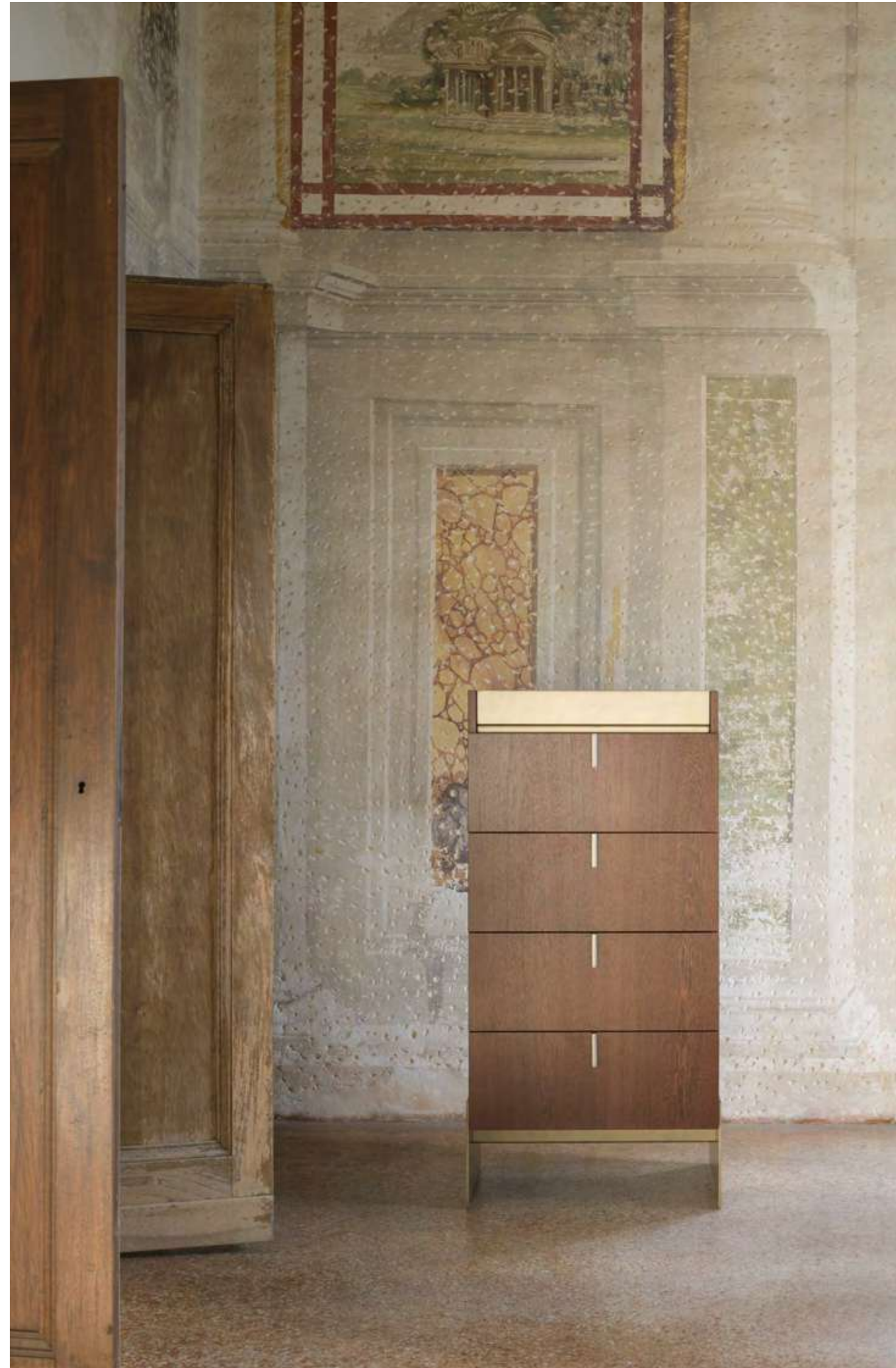

MAGIC HIGHBOY

AN ETHEREAL CELEBRATION OF UNIQUENESS AND UTMOST ALLURING BEAUTY. EACH PIECE IS CONCEIVED TO CONVEY A SENSE OF INTIMATE REFINEMENT AND ALCHEMICAL SOPHISTICATION. A DYNAMIC OXYMORON: CLEAN LINES AND SHAPES ARE JUXTAPOSED WITH THE CHOICE OF STRONG-CHARACTER MATERIALS, DARINGLY PAIRED TOGETHER.





TAMBOUR RUG





SOFAS



ALAYA ASIX → P. 174 ATRIUM → P. 175 COLINE → P. 176 LOUISE → P. 177 VAGUE → P. 178

MODULAR SOFAS



ALAYA → P. 180 ATRIUM → P. 182

ARMCHAIRS



ARAMIS → P. 184 JEAN → P. 184 TWILLY → P. 185 VAGUE → P. 185

SOFA TABLES



ALAYA central table → P. 186 ALAYA courtesy table → P. 186 ALLURE central table → P. 187 ALLURE side table → P. 187 ANTIBES central table → P. 188 PETITE side table → P. 191

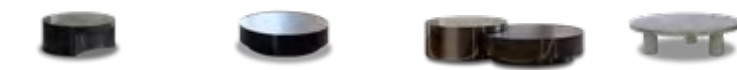

SOL side table → P. 188 SOL sofa table → P. 189 SOL sofa table composition → P. 189 TRUFFLE sofa table → P. 190

DINING TABLES



DOMINO top → P. 192 MIKADO top → P. 193 ORIGAMI top → P. 194 SEGMENTI top → P. 195



ANTIBES base → P. 196 CARTESIO base → P. 197 MEZZALUNA base → P. 198

CHAIRS



CLAIRE → P. 202 MAXIME → P. 200 MAXIME SOFT → P. 200 TWILLY → P. 201 TWILLY with arms → P. 201

BEDS



ASTORIA → P. 204 CHELSEA → P. 204 HYDE PARK → P. 205 SOHO → P. 205

BEDROOM COMPLEMENTS



ANTIBES chest of drawers → P. 206 ANTIBES night table → P. 206 MAGIC chest of drawers → P. 207 MAGIC dressing → P. 207 MAGIC highboy → P. 208 MAGIC night table → P. 208

CUPBOARDS AND LIBRARIES



MEMORIES display cabinet → P. 211 MONTREAL bookshelf → P. 212 NUAGE sideboard → P. 210 NUAGE tv cabinet → P. 210

OCCASIONALS AND DESKS



ALAYA console → P. 214 GALA desk → P. 214 MEZZALUNA console → P. 216 MONTREAL backsofa console → P. 215 MONTREAL console → P. 215

DECORATIONS



ALLURE mirror → P. 218 HYDE PARK wall decoration → P. 218 REFLECT mirror → P. 219 SEGMENTI wall decoration → P. 219

RUGS



NOMAD → P. 220 TAMBOUR → P. 220

ALAYA ASIX sofa
Bernhardt & Vella



Solid wood frame, metal feet, finishing in MO.508 delabrè copper smooth, with detail in MO.503 brushed natural brass. Multiple density polyurethane foam for seat and body. Available in left and right higher back. Decorative pillows on request.

Editorial story → P.007
Materials & technical drawings → QR Code



ALAYA ASIX 2 seats

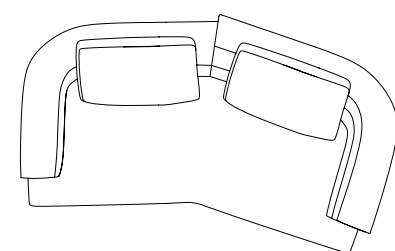
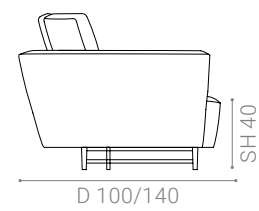
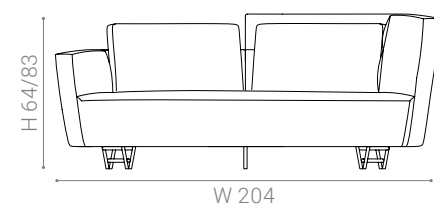

ALAYA ASIX 3 seats

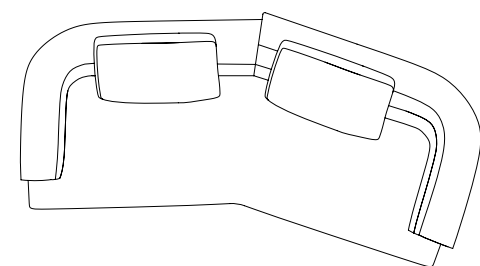
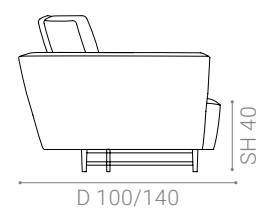
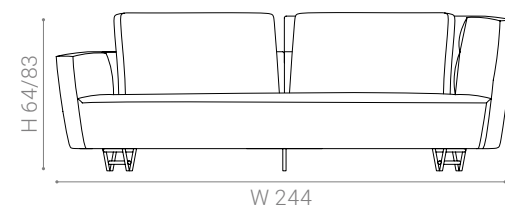

ALAYA ASIX 4 seats

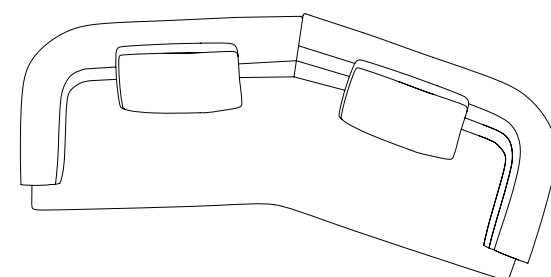
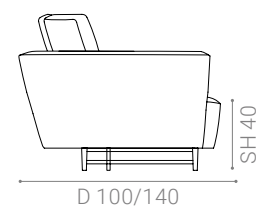
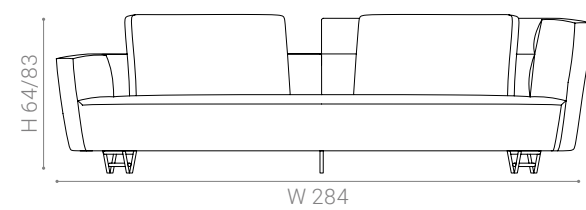

ATRIUM sofa
Bernhardt & Vella



Solid wood frame, metal base and shell, metallic finishing only. Seat and back cushions in natural feather with polyurethane insert. Decorative pillows on request.

Editorial story → P.051
Materials & technical drawings → QR Code



ATRIUM 2 seats

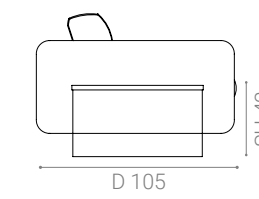
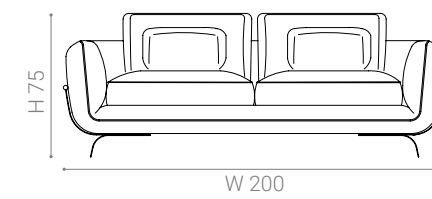

ATRIUM 3 seats

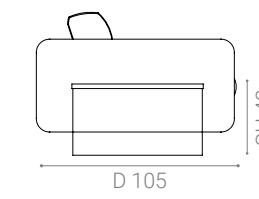
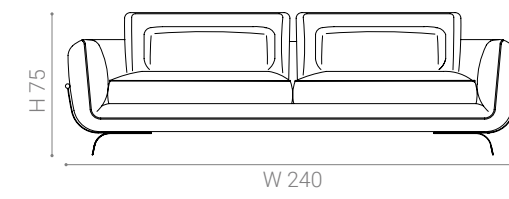

ATRIUM 4 seats

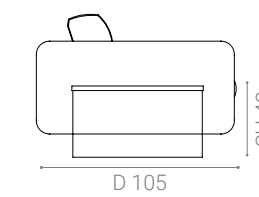
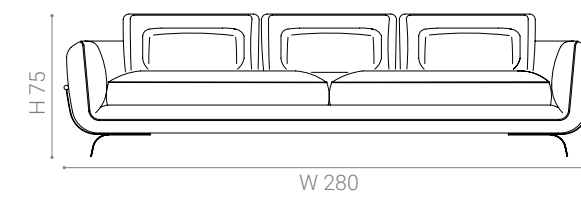

COLINE sofa
Bernhardt & Vella



Solid wood frame, metal feet, brushed metallic finishing only. Multiple density polyurethane foam for seat and body. Decorative pillows on request.

Editorial story → P. 083
Materials & technical drawings → QR Code



COLINE 2 seats

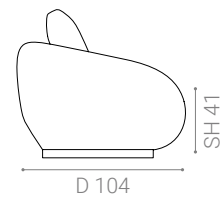
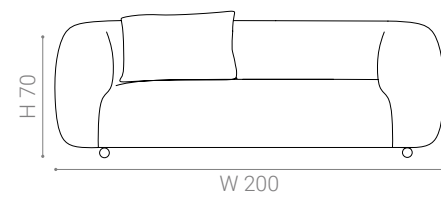

COLINE 3 seats

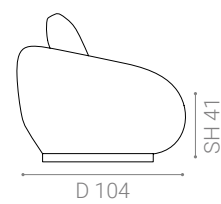
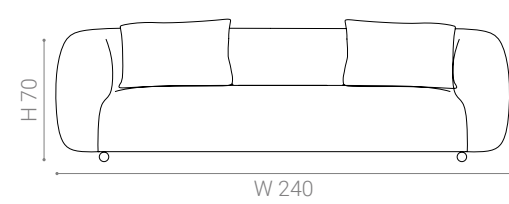

COLINE 4 seats

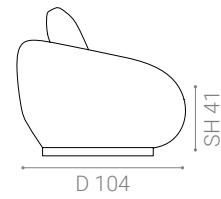
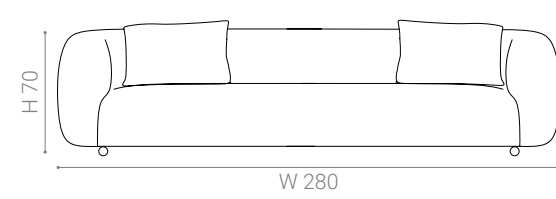

LOUISE sofa
Bernhardt & Vella



Solid wood frame, metal feet, finishing in MO.508 delabrè copper smooth. Multiple density polyurethane foam and feather for seat and body. Decorative pillows on request.

Editorial story → P. 075
Materials & technical drawings → QR Code



LOUISE 2 seats

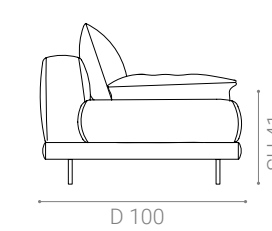
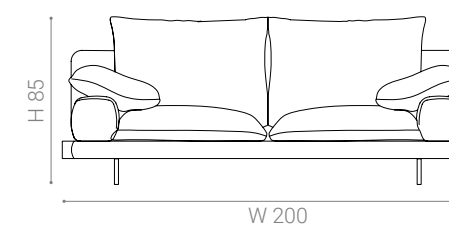

LOUISE 3 seats

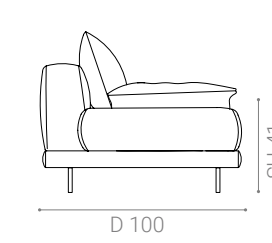
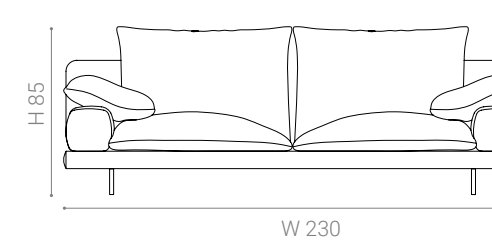

LOUISE 4 seats

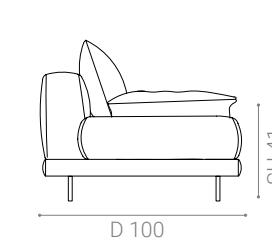
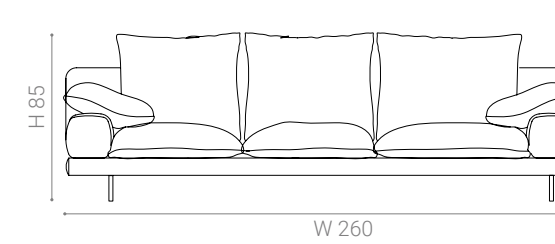

VAGUE sofa
Bernhardt & Vella



Solid wood frame, wooden base. Available in lacquered and metallic finishings. Seat cushions and back part in natural feather with polyurethane insert. Decorative pillows on request

Editorial story → P.065
Materials & technical drawings → QR Code



VAGUE 2 seats

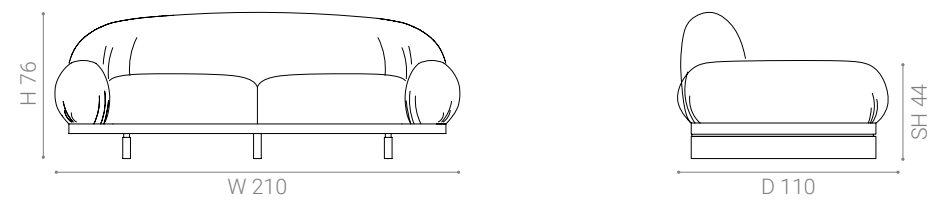

VAGUE 3 seats

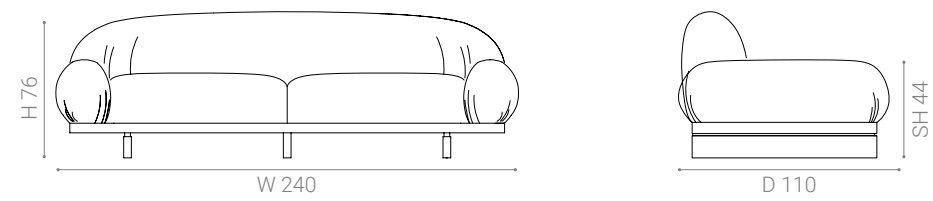

VAGUE 4 seats

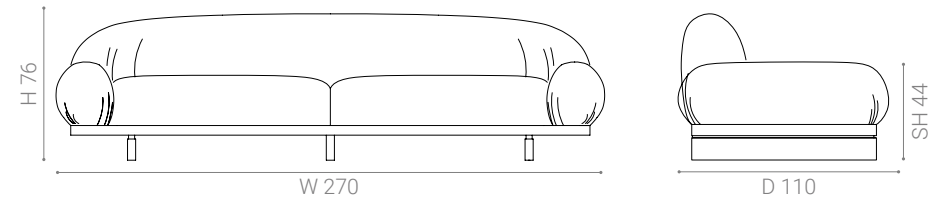

ALAYA modular sofa
Bernhardt & Vella



Solid wood frame, metal feet, finishing in MO.508 delabrè copper smooth, with detail in MO.503 brushed natural brass. Multiple density polyurethane foam for seat and body. Available in left and right element. Decorative pillows on request.

Editorial story → P.020
Materials & technical drawings → QR Code

ALAYA side element low 135

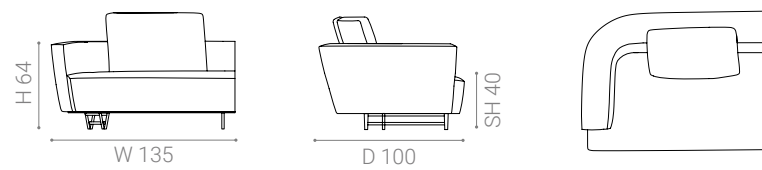

ALAYA side element high 135

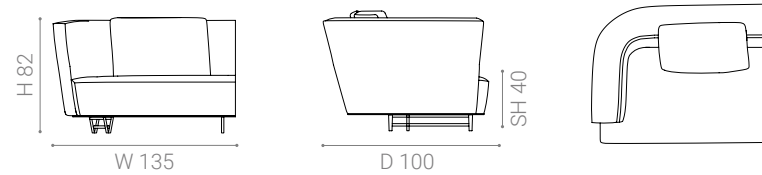

ALAYA side element low 220

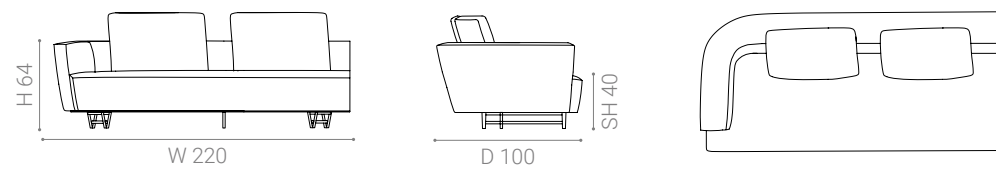

ALAYA side element high 220

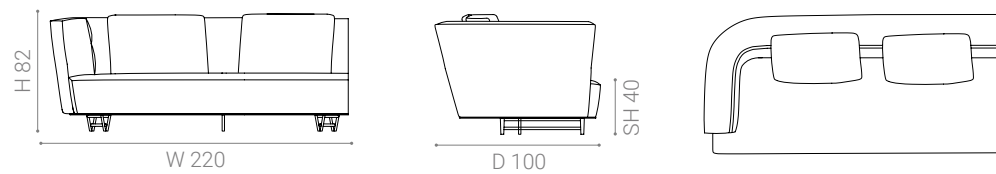

ALAYA side element low corner short

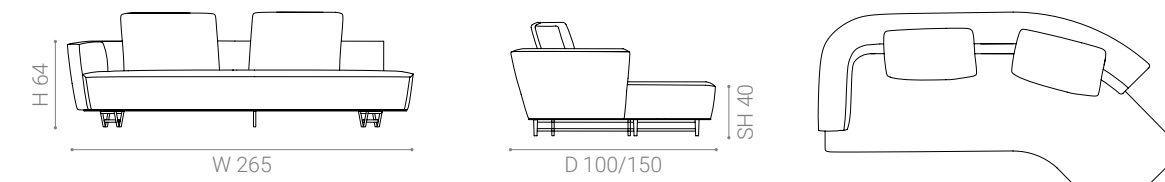

ALAYA side element high corner short

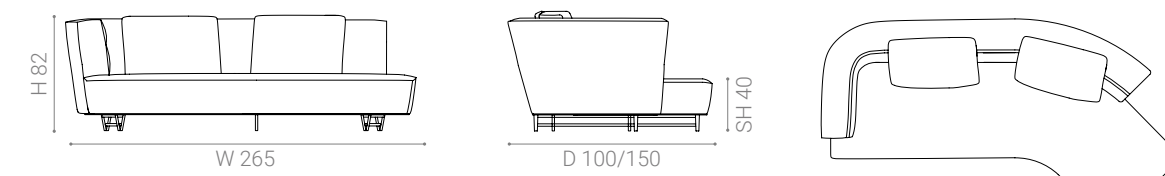

ALAYA side element low dormeuse

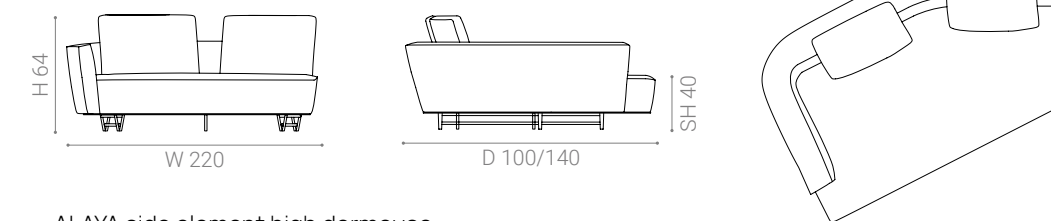

ALAYA side element high dormeuse

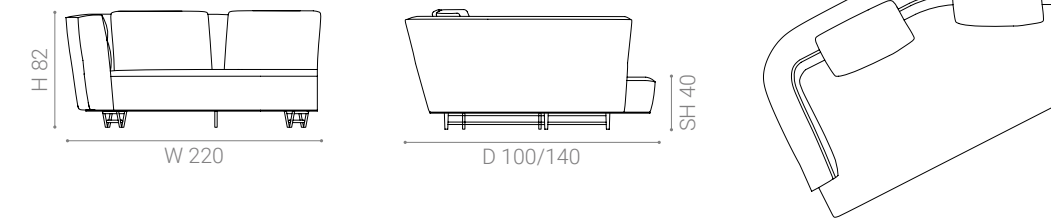

ATRIUM modular sofa
Bernhardt & Vella



Solid wood frame, metal base and shell, metallic finishing only. Seat and back cushions in natural feather with polyurethane insert. Available in left and right element. Decorative pillows on request.

Editorial story → P. 037
Materials & technical drawings → QR Code

ATRIUM side element 115

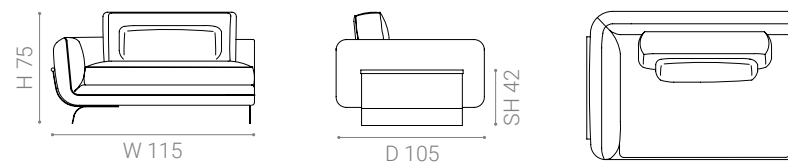

ATRIUM corner element

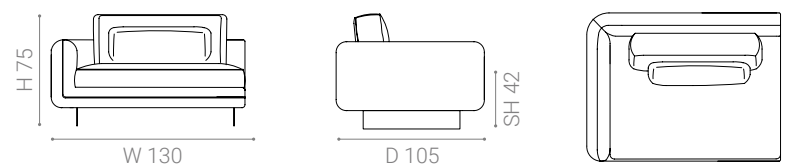

ATRIUM side element 200 double cushion

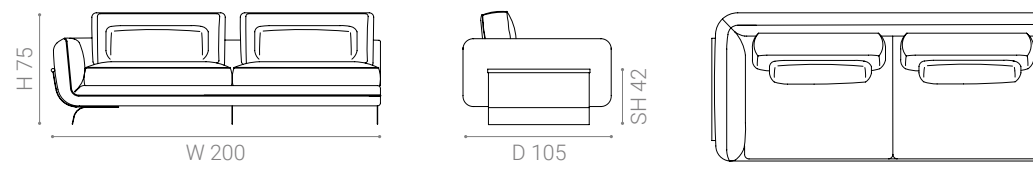

ATRIUM side element 200 single cushion + pouf

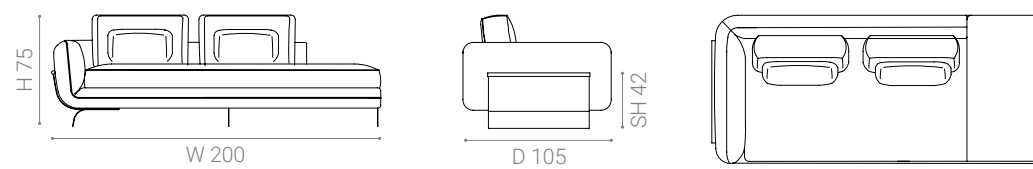

ATRIUM side element 200 single cushion + marble top

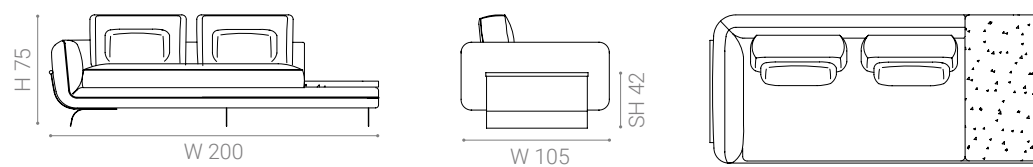

ATRIUM side element 250 single cushion + pouf

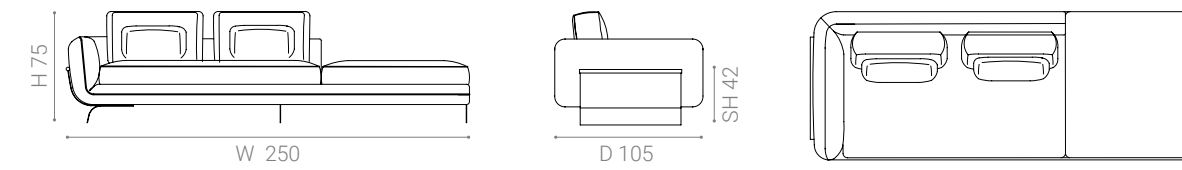

ATRIUM side element 250 single cushion + marble top

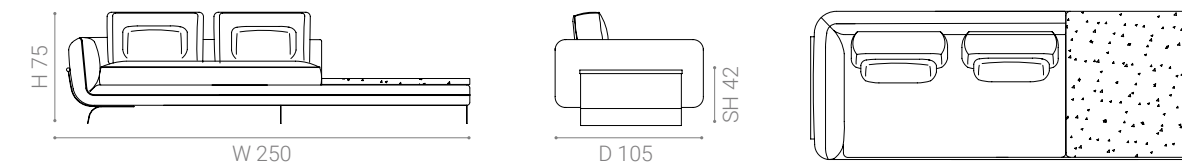

ATRIUM side element 250 double cushion + pouf

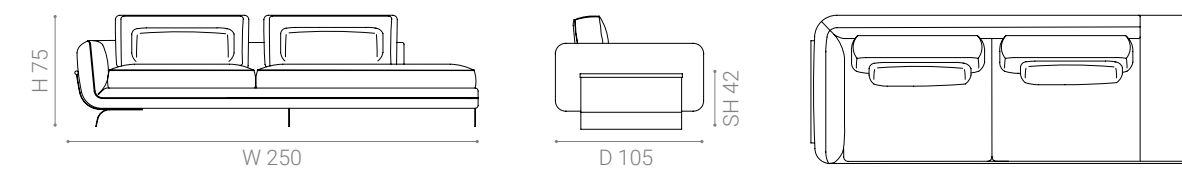

ATRIUM side element 250 double cushion + marble top

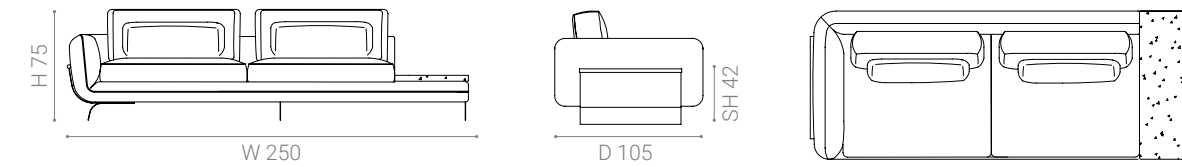

ATRIUM chaise longue

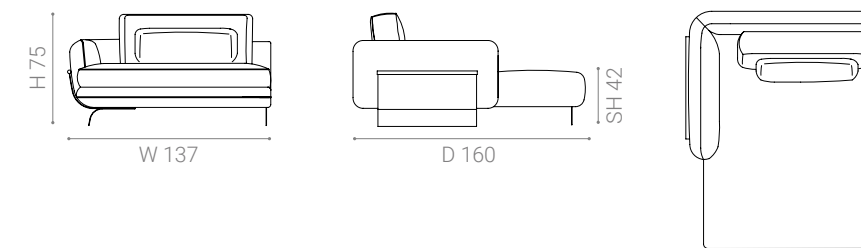

ATRIUM pouf

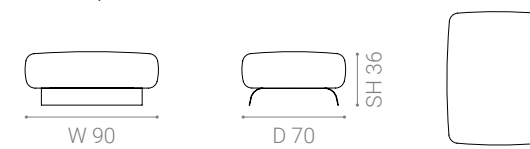

ARAMIS armchair
Bernhardt & Vella

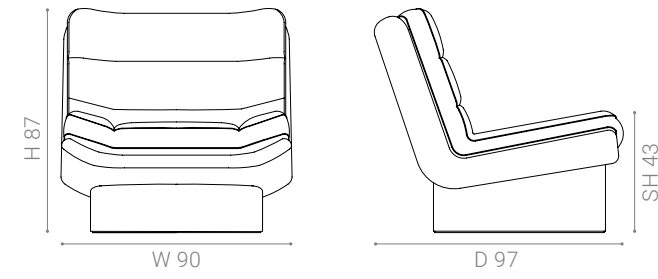

Solid wood frame, swivel base, metallic finishing only. Seat and back padding in multi-density polyurethane foam.

Editorial story → P. 025
Materials & technical drawings → QR Code



TWILLY armchair
Bernhardt & Vella

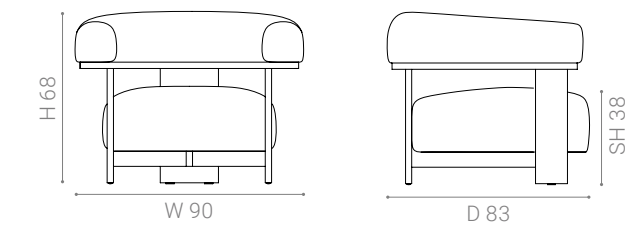

Solid wood frame, lacquered finishing only. Seat and back padding in multi-density polyurethane foam.

Editorial story → P. 015
Materials & technical drawings → QR Code



JEAN armchair
Bernhardt & Vella

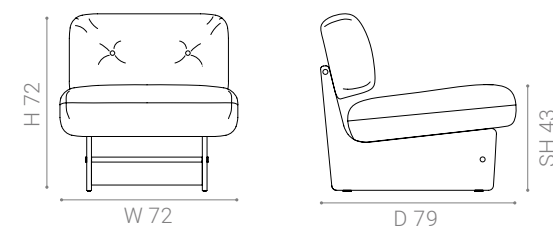

Plywood base, available in Onyge veneer, metal details. Seat and back cushions in multi-density polyurethane foam.

Editorial story → P. 045
Materials & technical drawings → QR Code



VAGUE armchair
Bernhardt & Vella

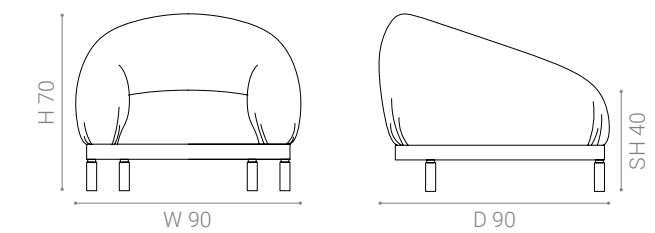

Solid wood frame, wooden base. Available in lacquered and metallic finishings. Seat cushions and back part in natural leather with polyurethane insert.

Editorial story → P. 061
Materials & technical drawings → QR Code



ALAYA central table
Bernhardt & Vella

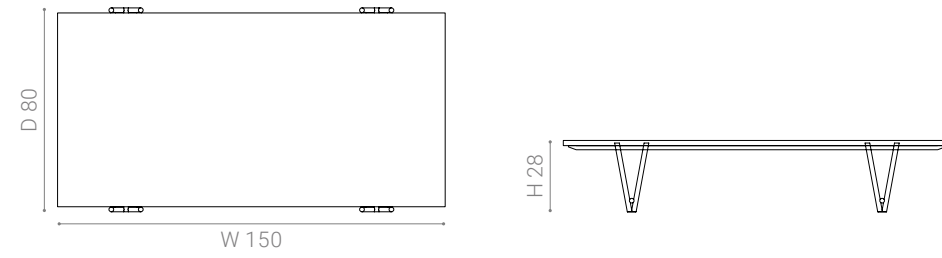

Metal base, finishing in MO.508 delabrè copper smooth, with detail in MO.503 brushed natural brass. Top available in bi color Onyge marquetry or marble only.

Editorial story → P. 013
Materials & technical drawings → QR Code



ALLURE central table
Bernhardt & Vella

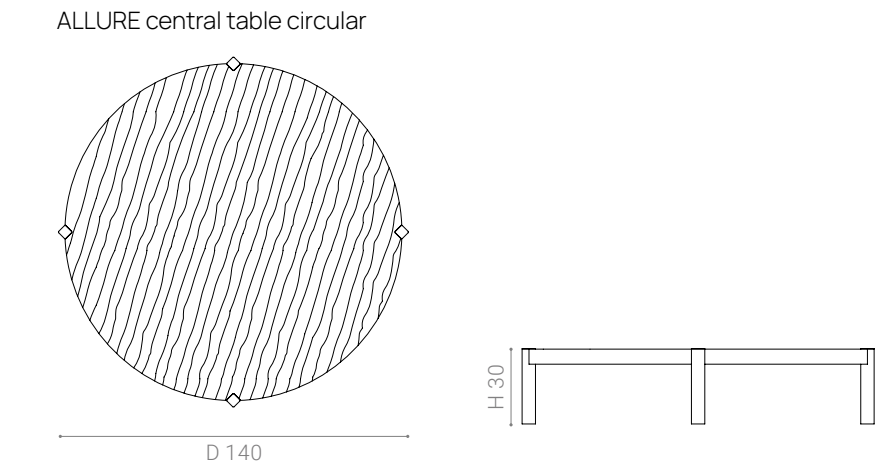
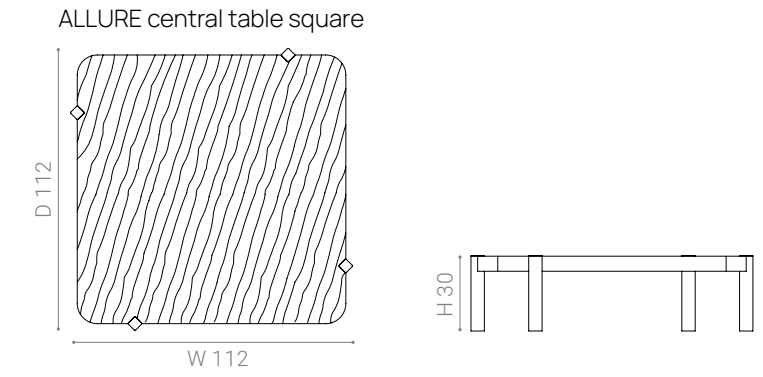

Plywood structure, available in Onyge marquetry only. Metal details.

Editorial story → P. 031
Materials & technical drawings → QR Code



ALAYA courtesy table
Bernhardt & Vella

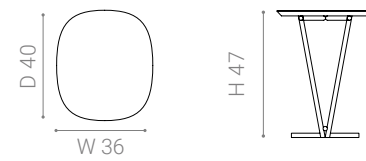

Metal base, finishing in MO.508 delabrè copper smooth, with detail in MO.503 brushed natural brass. Top available in bi color Onyge marquetry or marble only.

Editorial story → P. 011
Materials & technical drawings → QR Code



ALLURE side table
Bernhardt & Vella

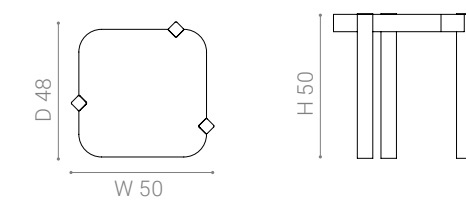

Plywood structure, lacquered and metallic finishing only.

Editorial story → P. 055
Materials & technical drawings → QR Code



ANTIBES central table
Bernhardt & Vella

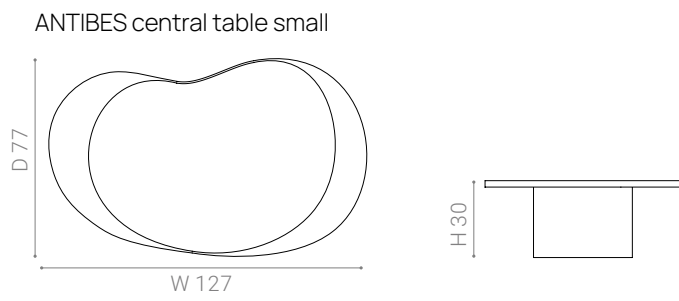
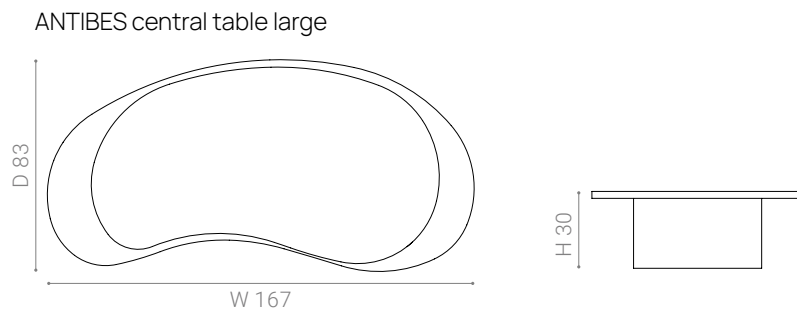
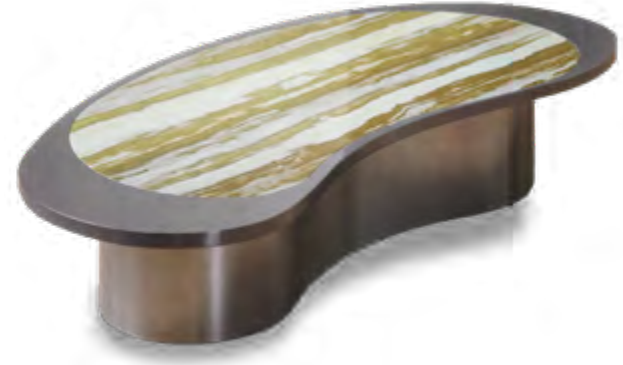

Wooden structure, lacquered and metallic finishing. Top available in wood or marble.

Editorial story → P. 022
Materials & technical drawings → QR Code



SOL sofa table
Bernhardt & Vella

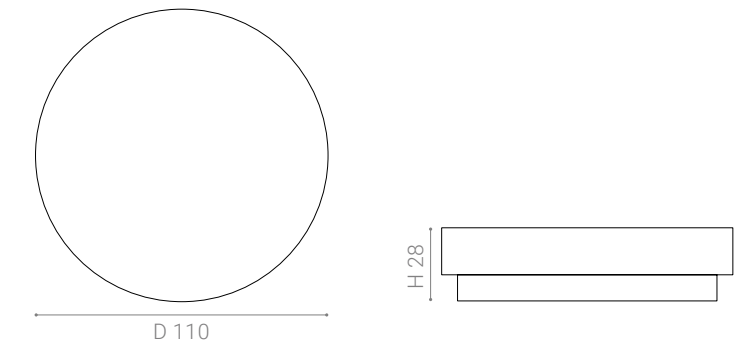
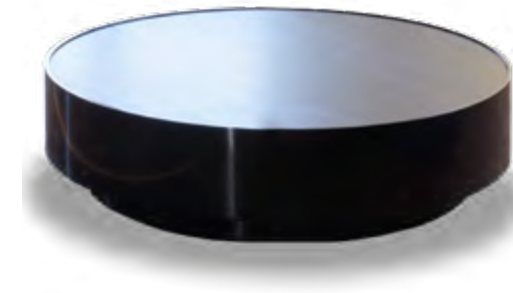

Wooden structure, lacquered and metallic finishing. Top available in Onyge veneer or marble.

Editorial story → P. 088
Materials & technical drawings → QR Code



SOL side table
Bernhardt & Vella

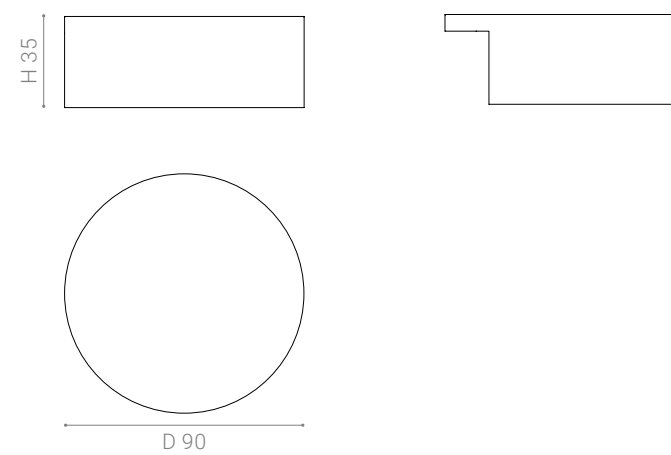
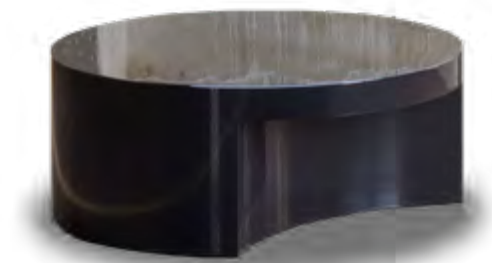

Wooden structure, lacquered and metallic finishing. Top available in Onyge veneer or marble.

Editorial story → P. 088
Materials & technical drawings → QR Code



SOL sofa table composition
Bernhardt & Vella

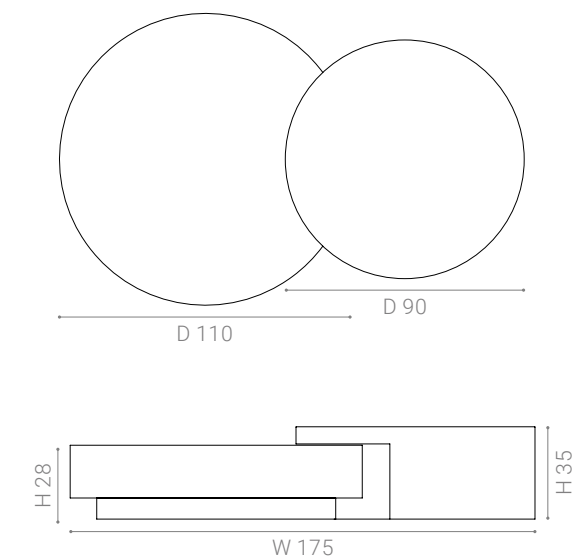
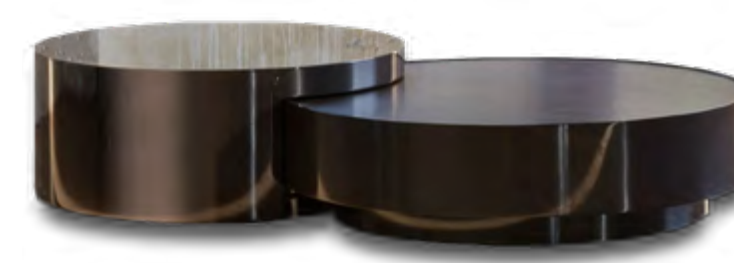

Wooden structure, lacquered and metallic finishing. Top available in Onyge veneer or marble.

Editorial story → P. 089
Materials & technical drawings → QR Code



TRUFFLE sofa table
Bernhardt & Vella



TRUFFLE 120 sofa table

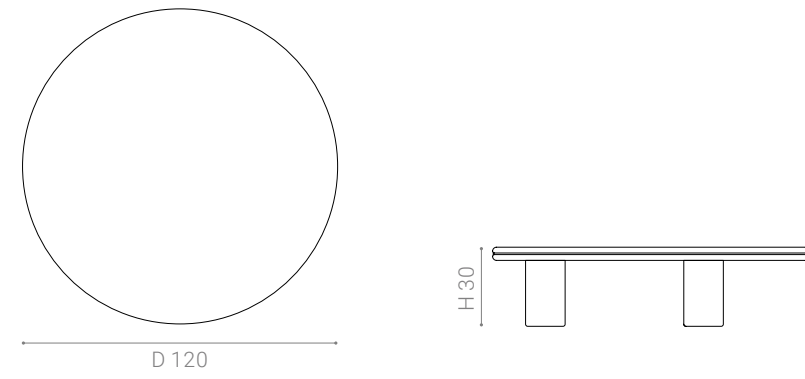

Wooden structure, available in metallic and lacquered finishing only.

Editorial story → P. 081
Materials & technical drawings → QR Code



TRUFFLE 80 sofa table

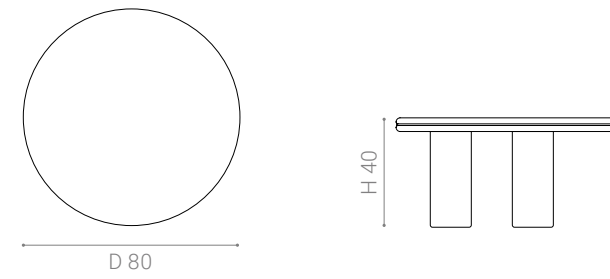

TRUFFLE 45 sofa table
Bernhardt & Vella

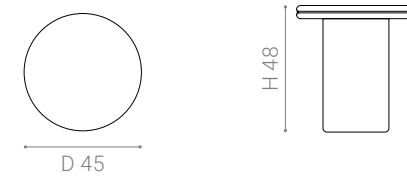

Wooden structure, available in metallic and lacquered finishing only.

Editorial story → P. 081
Materials & technical drawings → QR Code



PETITE side table
Bernhardt & Vella

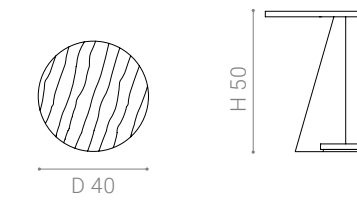

Plywood structure, available in Onyge veneer marquetry.

Editorial story → P. 042
Materials & technical drawings → QR Code



DOMINO table top
Bernhardt & Vella



DOMINO top

Plywood and mdf, lacquered finishing only.
Brushed metal details.

Editorial story → P.107
Materials & technical drawings → QR Code

DOMINO top for round table 160

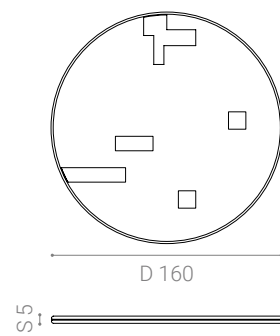

Base suitable for round top

ANTIBES base for round top

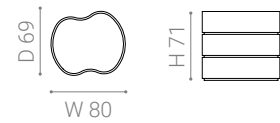

CARTESIO base for round top

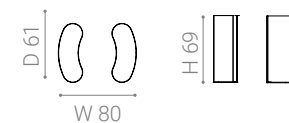

MEZZALUNA base for round top

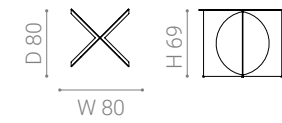

DOMINO top for oval table 240

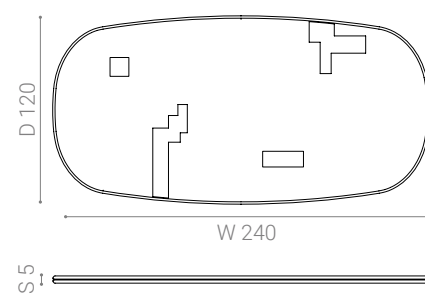

Base suitable for oval top

ANTIBES base for oval top

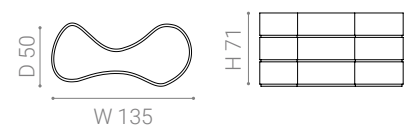

DOMINO top for oval table 300

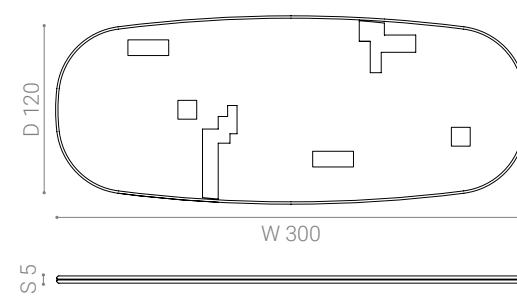

CARTESIO base for oval top

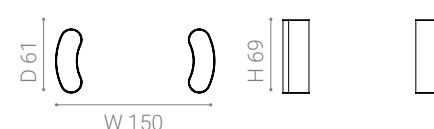

MEZZALUNA base oval round top



MIKADO table top
Bernhardt & Vella

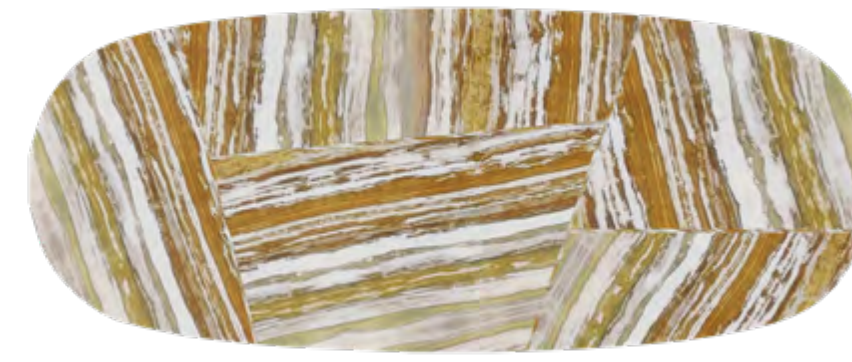

MIKADO top

Composite marble with wooden backing.

Editorial story → P.124
Materials & technical drawings → QR Code

MIKADO top for round table 160

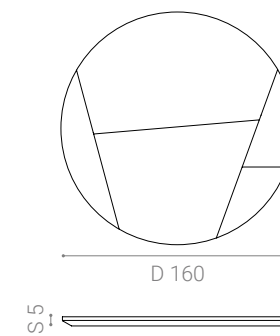

Base suitable for round top

ANTIBES base for round top

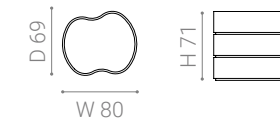

CARTESIO base for round top

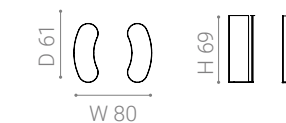

MEZZALUNA base for round top

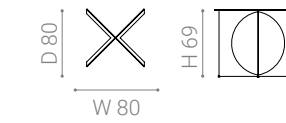

MIKADO top for oval table 240

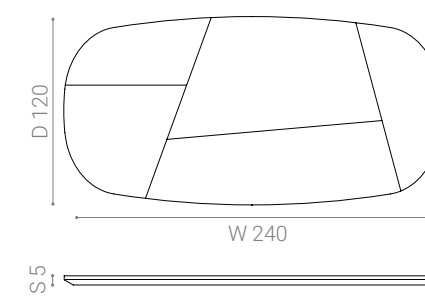

Base suitable for oval top

ANTIBES base for oval top

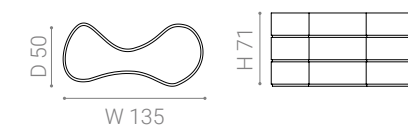

MIKADO top for oval table 300

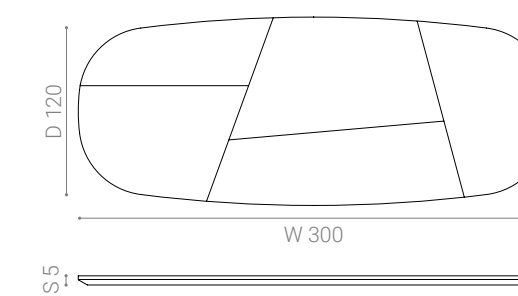

CARTESIO base for oval top

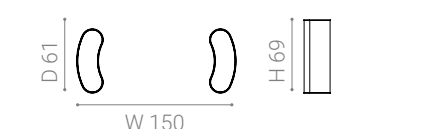

MEZZALUNA base oval round top



ORIGAMI table top
Bernhardt & Vella



ORIGAMI top

Plywood top with marquetry, available in MO.350 Onyge brown veneer and MO.351 Onyge black veneer, only.

Editorial story → P.103
Materials & technical drawings → QR Code

SEGMENTI table top
Bernhardt & Vella



SEGMENTI top

Plywood top with marquetry, available in MO.352 Onyge red veneer and metal insert in MO.506 brushed silver brass.

Editorial story → P.097
Materials & technical drawings → QR Code

ORIGAMI top for round table 160

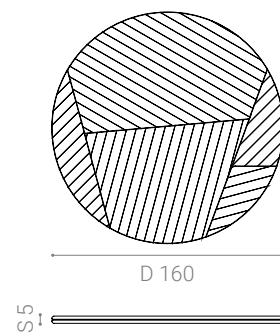

Base suitable for round top

ANTIBES base for round top

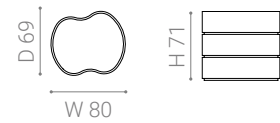

CARTESIO base for round top

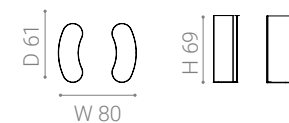

MEZZALUNA base for round top

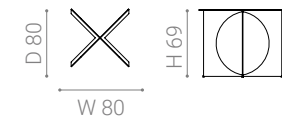

SEGMENTI top for round table 160

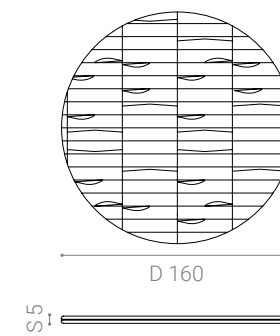

Base suitable for round top

ANTIBES base for round top

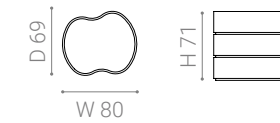

CARTESIO base for round top



MEZZALUNA base for round top

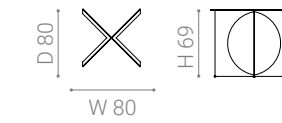

ORIGAMI top for oval table 240

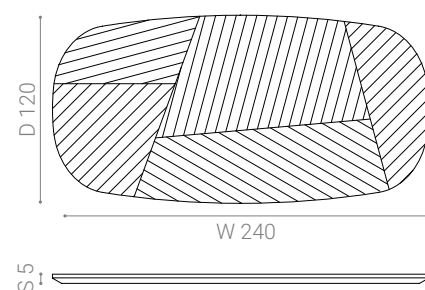

Base suitable for oval top

ANTIBES base for oval top

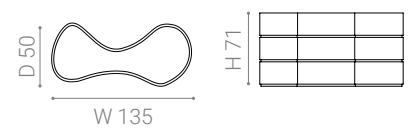

ORIGAMI top for oval table 300

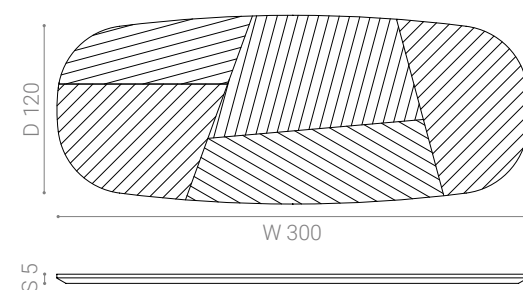

CARTESIO base for oval top

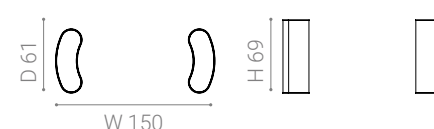

MEZZALUNA base oval round top



SEGMENTI top for oval table 240

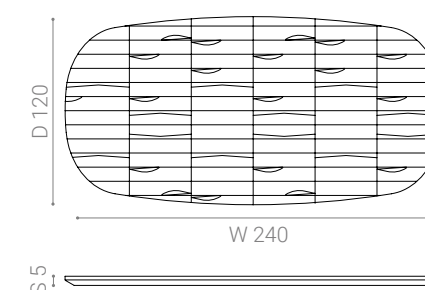

Base suitable for oval top

ANTIBES base for oval top

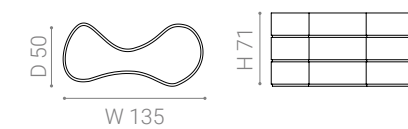

SEGMENTI top for oval table 300

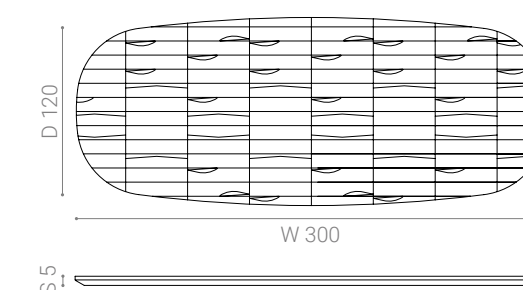

CARTESIO base for oval top

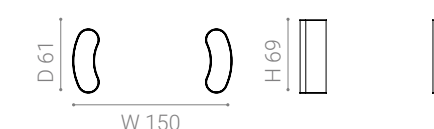

MEZZALUNA base oval round top



ANTIBES table base
Bernhardt & Vella



ANTIBES base

Wooden structure, metallic finishing only.
Available for oval and round top.

Editorial story → P. 107
Materials & technical drawings → QR Code



CARTESIO table base
Bernhardt & Vella



CARTESIO base

Base composed by 2 elements, wooden structure, leather padded.
Available for oval and round top.

Editorial story → P. 120
Materials & technical drawings → QR Code



ANTIBES base for round table

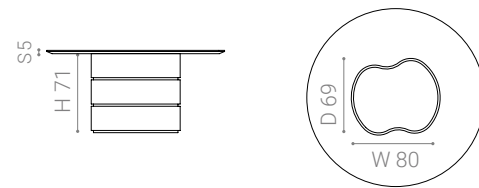

Top suitable for round base

DOMINO top for round table

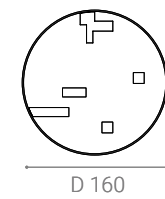

MIKADO top for round table

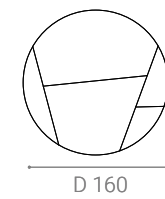

ORIGAMI top for round table

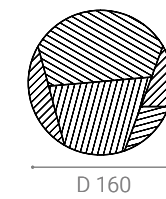

SEGMENTI top for round table

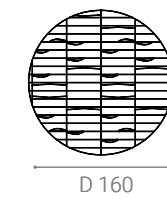

ANTIBES base for oval table

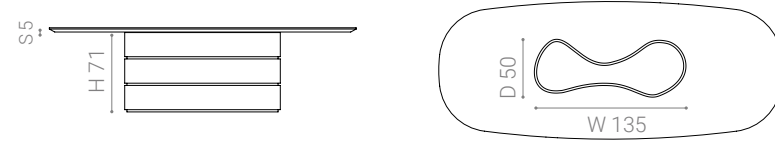

Top suitable for oval base

DOMINO top for oval table

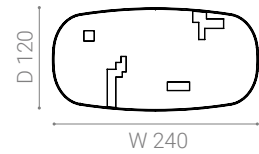

MIKADO top for oval table

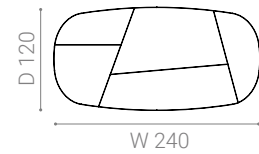

ORIGAMI top for oval table

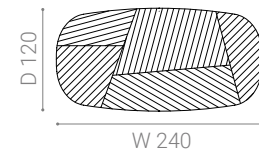

SEGMENTI top for oval table

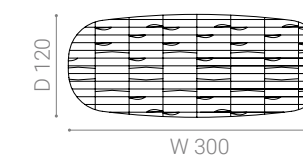
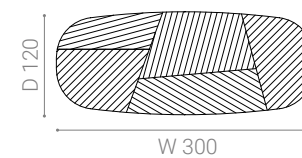
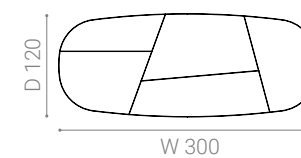
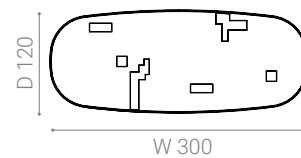
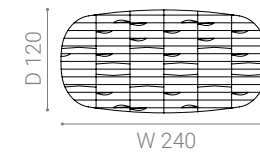

CARTESIO base for round table

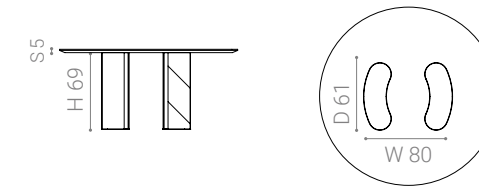

Top suitable for round base

DOMINO top for round table

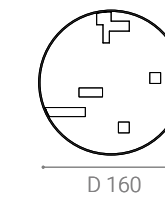

MIKADO top for round table

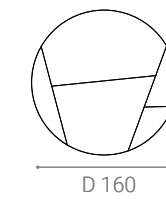

ORIGAMI top for round table

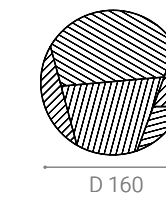

SEGMENTI top for round table

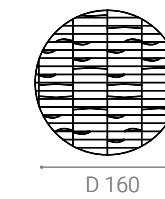

CARTESIO base for oval table

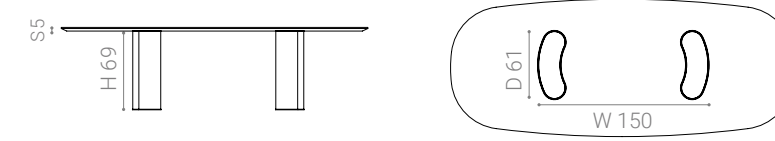

Top suitable for oval base

DOMINO top for oval table

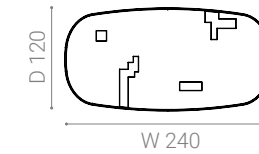

MIKADO top for oval table

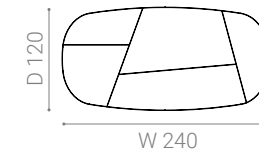

ORIGAMI top for oval table

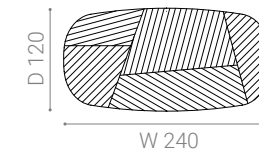

SEGMENTI top for oval table

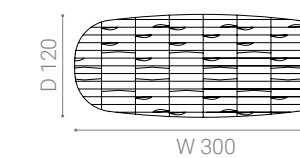
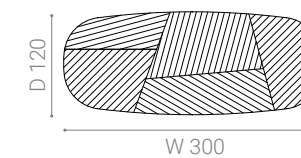
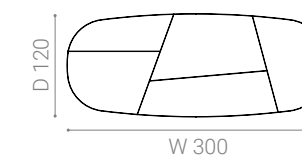
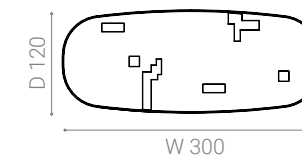
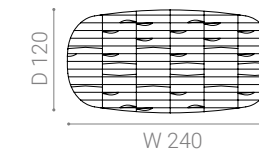

MEZZALUNA table base
Bernhardt & Vella



MEZZALUNA base

Metal structure , laser cut, lacquered
and metallic finishing.
Available for oval and round top.

Editorial story → P. 097
Materials & technical drawings → QR Code



MEZZALUNA base for round table

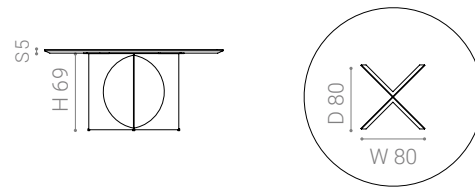

Top suitable for round base

DOMINO top for round table

MIKADO top for round table

ORIGAMI top for round table

SEGMENTI top for round table

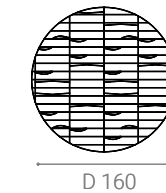
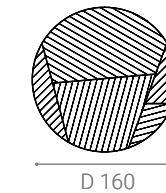
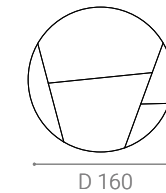
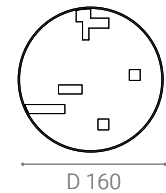

MEZZALUNA base for oval table

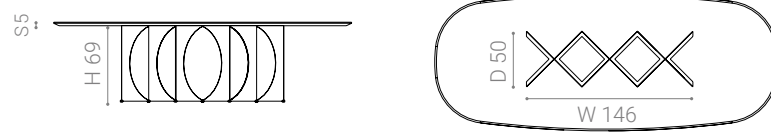

Top suitable for oval base

DOMINO top for oval table

MIKADO top for oval table

ORIGAMI top for oval table

SEGMENTI top for oval table

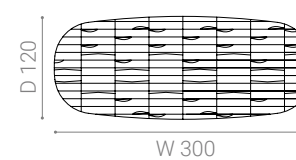
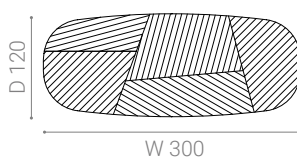
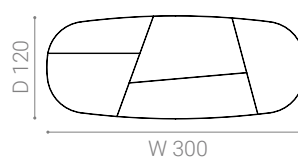
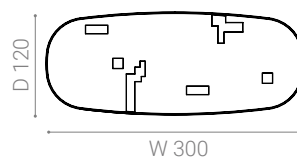
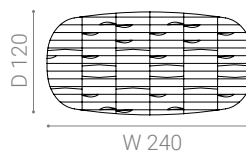
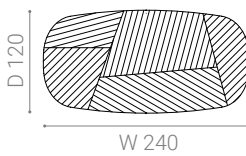
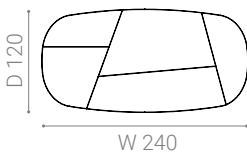
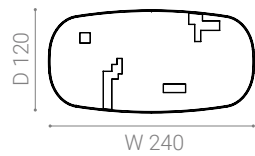

MAXIME chair
Bernhardt & Vella

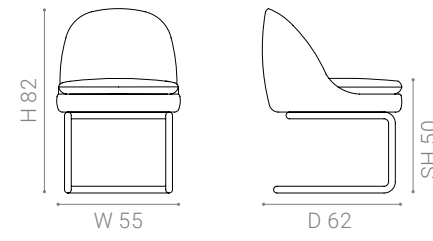

Metal frame, multi-density polyurethane foam padding. Metal base in lacquered and metallic finishing.

Editorial story → P. 110
Materials & technical drawings → QR Code



TWILLY chair
Bernhardt & Vella

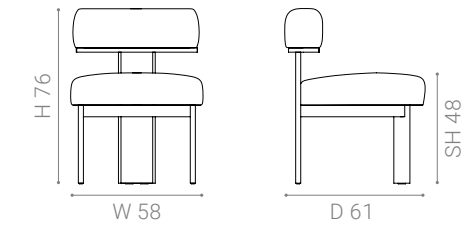

Solid wood frame, lacquered finishing only. Seat and back padding in multi-density polyurethane foam.

Editorial story → P. 104
Materials & technical drawings → QR Code



MAXIME SOFT chair
Bernhardt & Vella

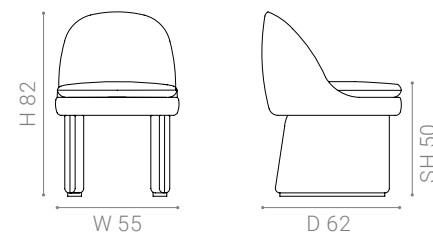

Metal frame, multi-density polyurethane foam padding. Upholstered wooden base.

Editorial story → P. 099
Materials & technical drawings → QR Code



TWILLY chair with arms
Bernhardt & Vella

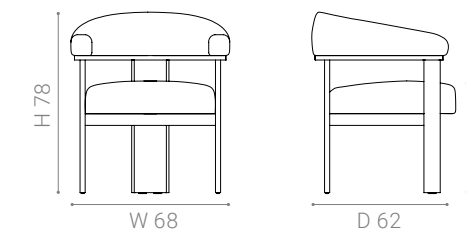

Solid wood frame, lacquered finishing only. Seat and back padding in multi-density polyurethane foam.

Editorial story → P. 092
Materials & technical drawings → QR Code

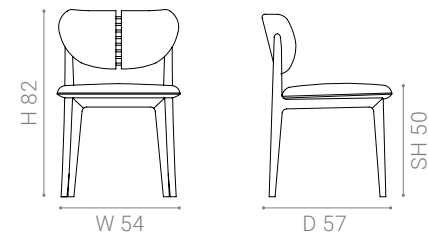

CLAIRE chair
Bernhardt & Vella

Oak solid wood frame, tinted finishing
with metal details in MO. 508 delabrè copper
smooth. Seat and back padding
in multi-density polyurethane foam.

Editorial story → P. 128
Materials & technical drawings → QR Code



MONOGRAPHY

ASTORIA bed
Bernhardt & Vella

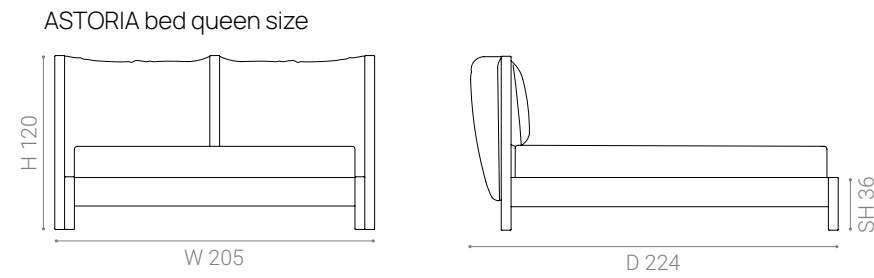
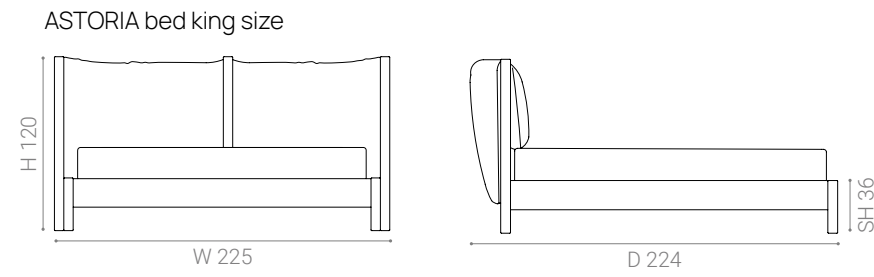

Solid wood and plywood structure.
Lacquered and metallic finishing.
Multiple densities polyurethane foam padding. Available in queen and king size.
Wooden slat included.

Editorial story → P.139
Materials & technical drawings → QR Code



SENSUAL HOME

HYDE PARK bed
Bernhardt & Vella

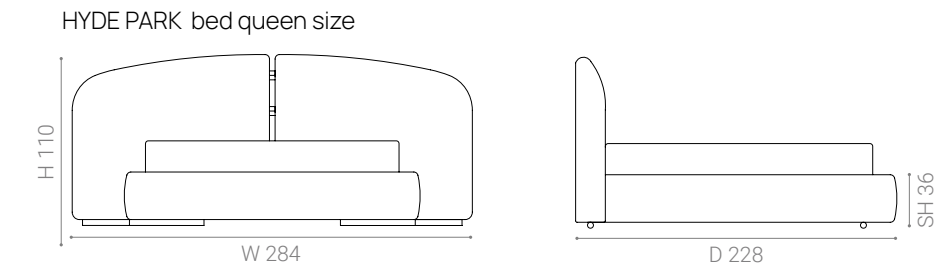
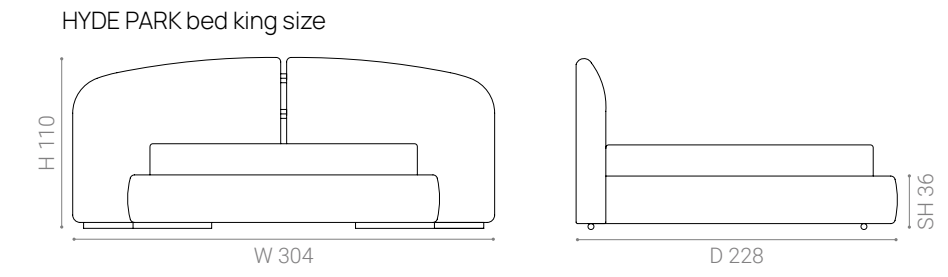

Solid wood and plywood structure, brushed metallic finishing only. Multiple densities polyurethane foam padding. Available in queen and king size. Wooden slat included.

Editorial story → P.143
Materials & technical drawings → QR Code



CHELSEA bed
Bernhardt & Vella

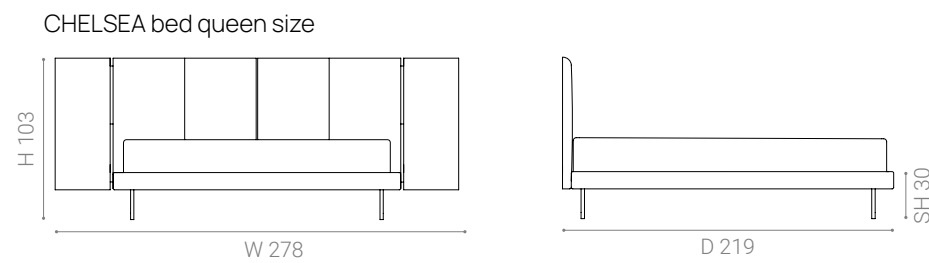
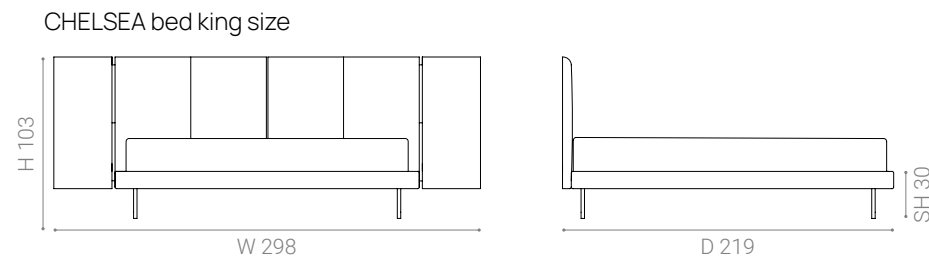

Solid wood frame, metal feet, finishing in MO.508 delabrè copper smooth only. Multiple densities polyurethane foam padding. Available in queen and king size. Wooden slat included.

Editorial story → P.153
Materials & technical drawings → QR Code



SOHO bed
Bernhardt & Vella

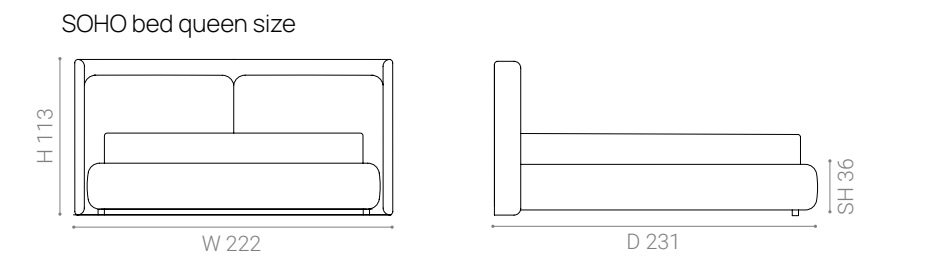
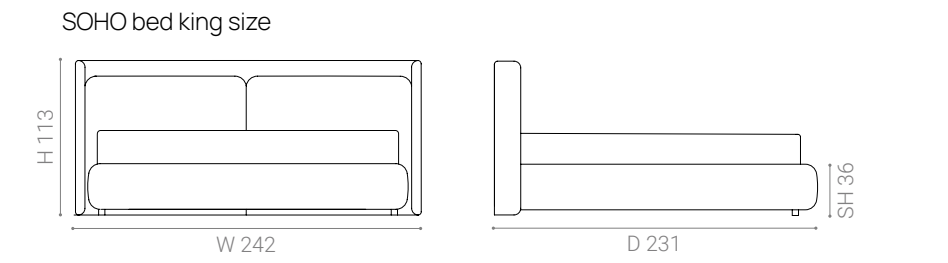

Solid wood and plywood structure. Metal details brushed metallic finishing only. Multiple densities polyurethane foam padding. Available in queen and king size. Wooden slat included.

Editorial story → P.133
Materials & technical drawings → QR Code



ANTIBES chest of drawers
Bernhardt & Vella

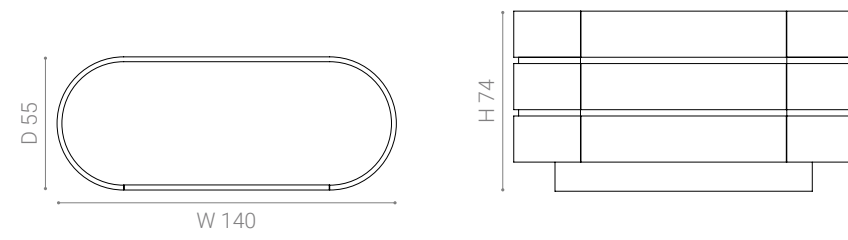

Plywood structure, lacquered and metallic finishing. Top in lacquered wood or marble.

Editorial story → P. 137
Materials & technical drawings → QR Code



MAGIC chest of drawers
Bernhardt & Vella

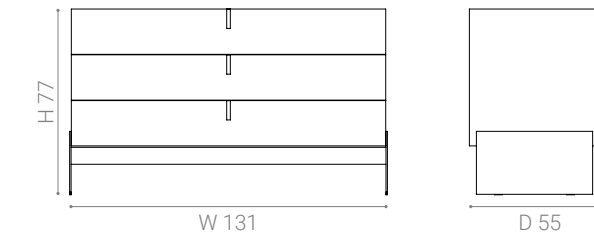
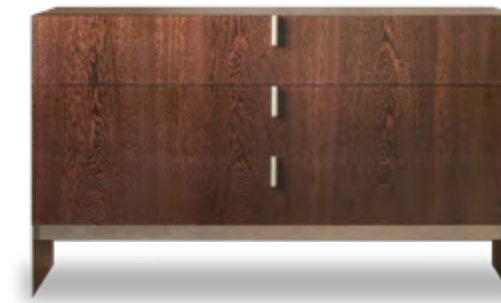

Plywood structure, lacquered and metallic finishing. Top in lacquered wood or marble.

Editorial story → P. 156
Materials & technical drawings → QR Code



ANTIBES night table
Bernhardt & Vella

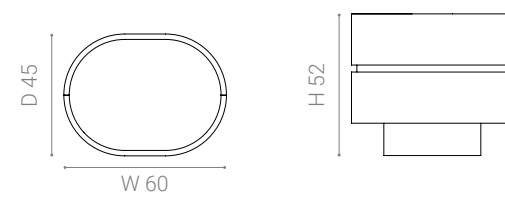

Plywood structure, lacquered and metallic finishing. Top in lacquered wood or marble.

Editorial story → P. 137
Materials & technical drawings → QR Code



MAGIC dressing
Bernhardt & Vella

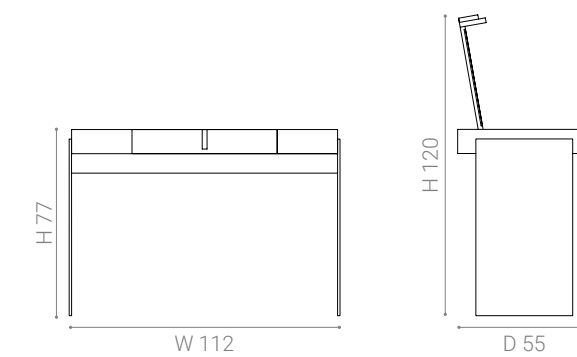

Plywood structure, available in leather or intreccio leather. Metal base in metallic smooth finishing only.

Editorial story → P. 161
Materials & technical drawings → QR Code



MAGIC highboy
Bernhardt & Vella

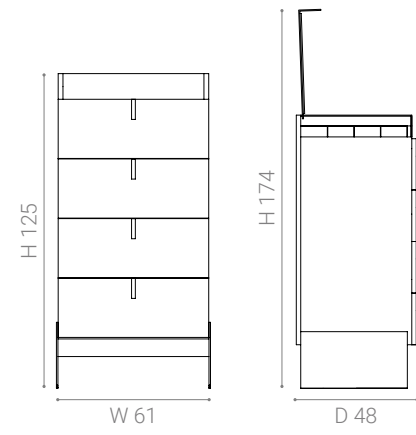

Plywood structure, available in Onyge veneer only. Metal base in metallic smooth finishing only.

Editorial story → P. 162
Materials & technical drawings → QR Code



MAGIC night table
Bernhardt & Vella

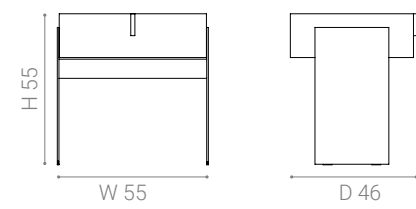

Plywood structure, available in Onyge veneer only. Metal base in metallic smooth finishing only.

Editorial story → P. 159
Materials & technical drawings → QR Code



NUAGE sideboard
Bernhardt & Vella

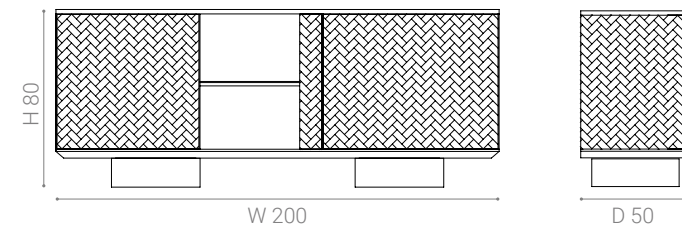

Solid wood and plywood structure.
Top available in Onyge veneer or marble.
Front part covered in leather or intreccio leather. Metal details in smooth finishing.

Editorial story → P. 112
Materials & technical drawings → QR Code



MEMORIES display cabinet
Bernhardt & Vella

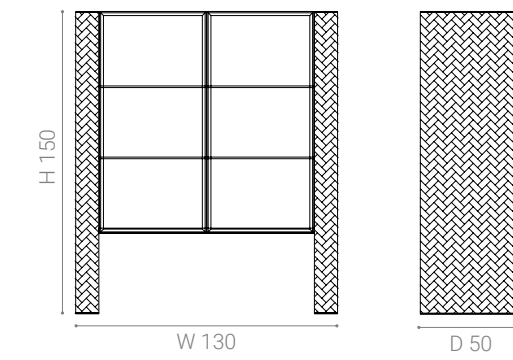
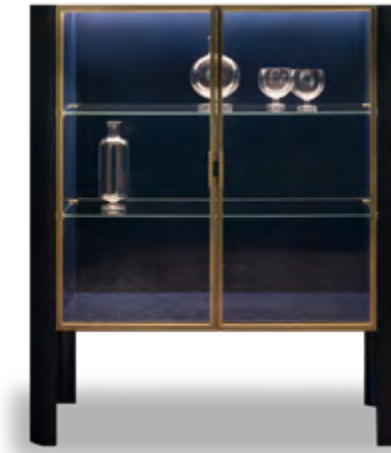

Solid wood and plywood structure.
Available in leather or intreccio leather on request. Metal frame doors, extrawhite glass. Internally fitted with crystal shelves and led light, in smooth lacquering (matching selected leather).

Editorial story → P. 115
Materials & technical drawings → QR Code



NUAGE tv cabinet
Bernhardt & Vella

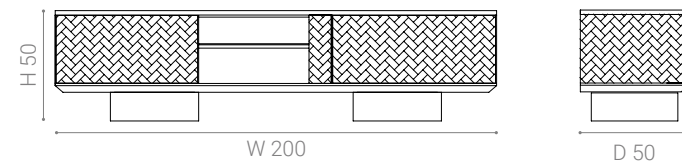

Solid wood and plywood structure.
Top available in Onyge veneer or marble.
Front part covered in leather or intreccio leather. Metal details in smooth finishing.

Editorial story → P. 069
Materials & technical drawings → QR Code



MONTREAL bookshelf
Bernhardt & Vella



Plywood structure, metallic finishing only.
Embossed bronze glass shelves,
metal details.

Editorial story → P. 057
Materials & technical drawings → QR Code

MONTREAL Bookshelf double 150 + 120

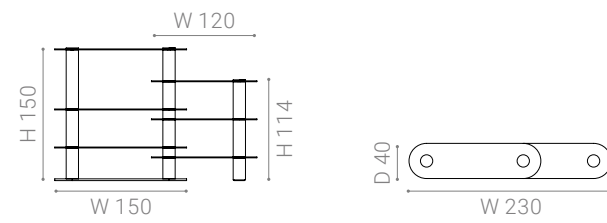

MONTREAL Bookshelf triple 120 + 150 + 120

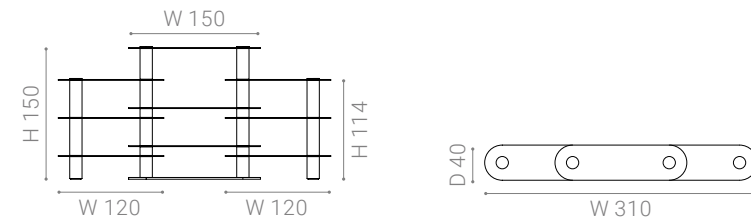

MONTREAL Bookshelf double 150 + 150

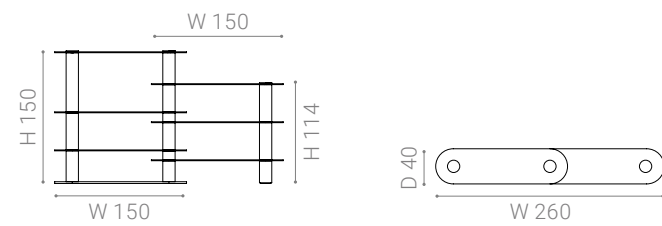

MONTREAL Bookshelf triple 150 + 150 + 150

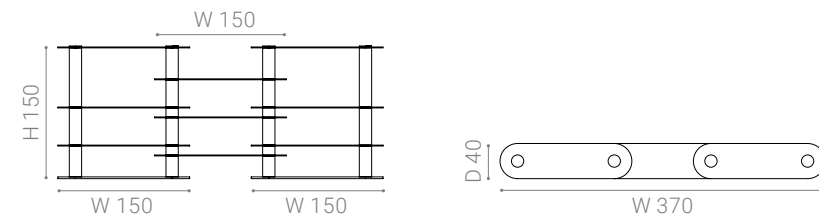

MONTREAL Bookshelf four elements 150 + 150 + 150 + 150

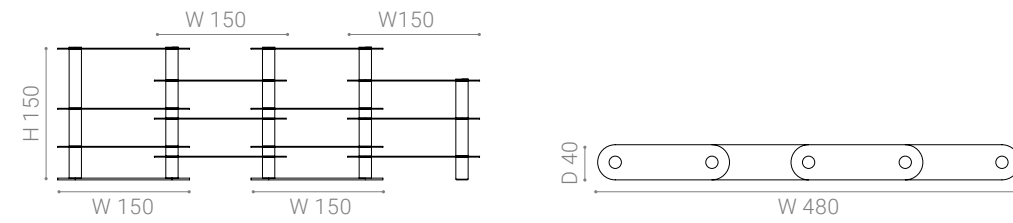

ALAYA console
Bernhardt & Vella

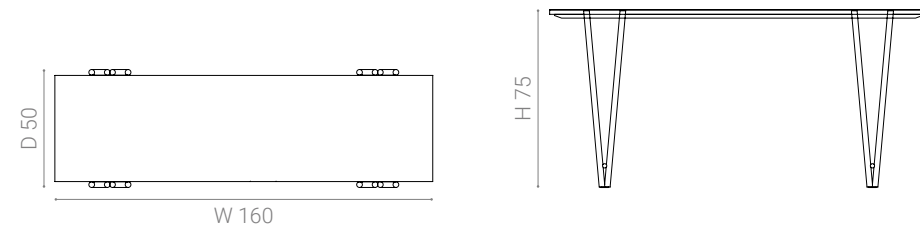

Metal base, finishing in MO.508 delabrè copper smooth, with detail in MO.503 brushed natural brass. Top available in bi color Onyge marquetry or marble only.

Editorial story → P. 012
Materials & technical drawings → QR Code



MONTREAL backsofa console
Bernhardt & Vella

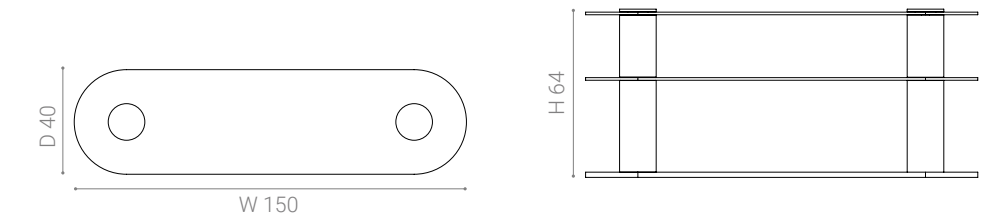

Plywood structure, metallic finishing only. Embossed bronze glass shelves, metal details.

Editorial story → P. 041
Materials & technical drawings → QR Code



GALA desk
Bernhardt & Vella

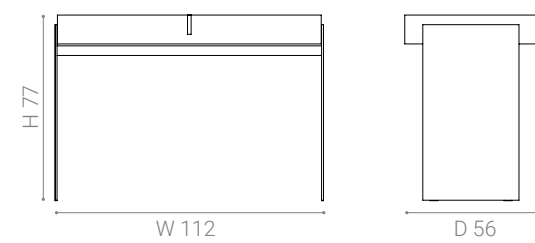

Plywood structure, available in Onyge veneer only. Metal base in metallic smooth finishing only.

Editorial story → P. 059
Materials & technical drawings → QR Code



MONTREAL console
Bernhardt & Vella

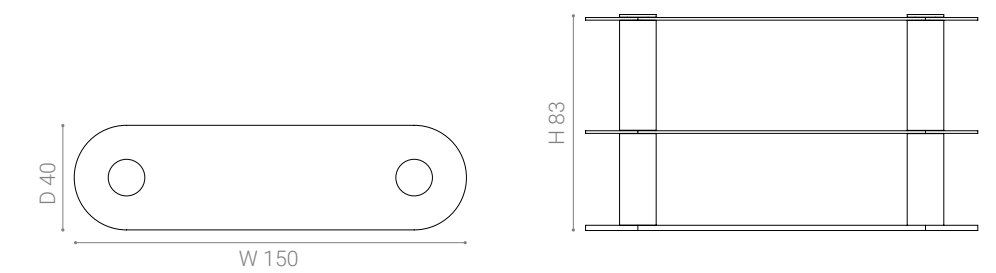

Plywood structure, metallic finishing only. Embossed bronze glass shelves, metal details.

Editorial story → P. 056
Materials & technical drawings → QR Code



MEZZALUNA console
Bernhardt & Vella

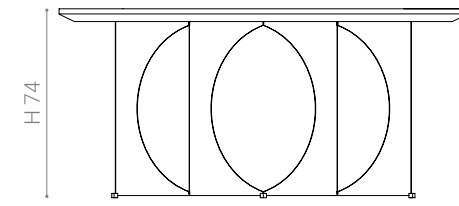
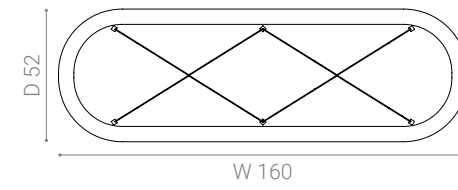

Metal structure, laser cut available
in lacquered or metallic finishing.
Top available in Onyge veneer or marble only.

Editorial story → P. 033
Materials & technical drawings → QR Code



ALLURE mirror
Bernhardt & Vella

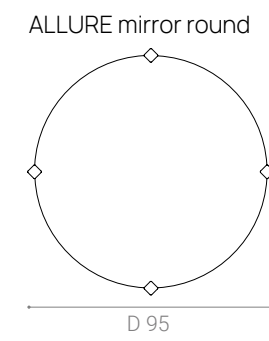
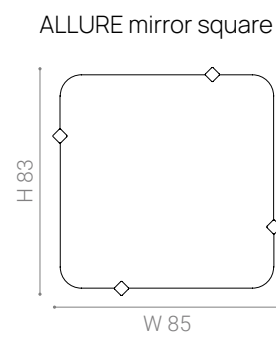

MDF frame with metal details in smooth finishing. Extra-white mirror.

Editorial story → P. 147
Materials & technical drawings → QR Code



REFLECT mirror
Bernhardt & Vella

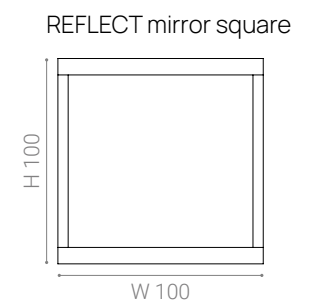
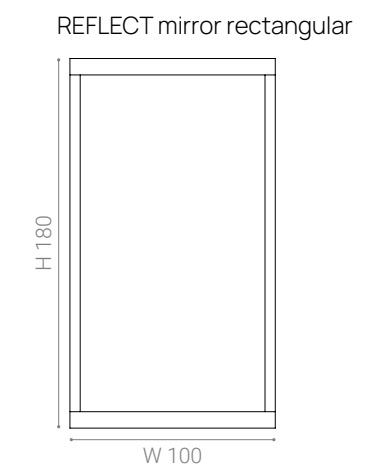

Plywood frame with solid wood decorations, metallic finishing in MO.510 chrome silver brass and MO.511 chrome natural brass. Extra-white mirror.

Editorial story → P. 071
Materials & technical drawings → QR Code



HYDE PARK wall decoration
Bernhardt & Vella

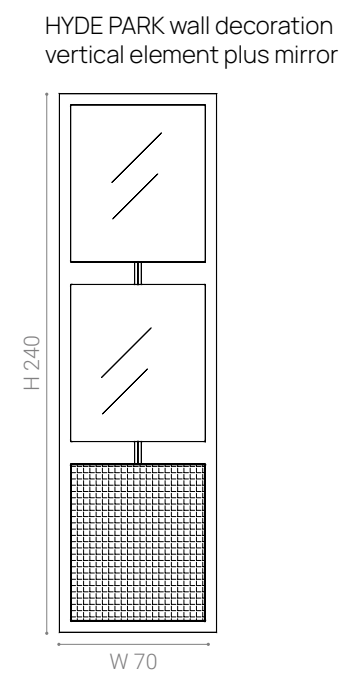
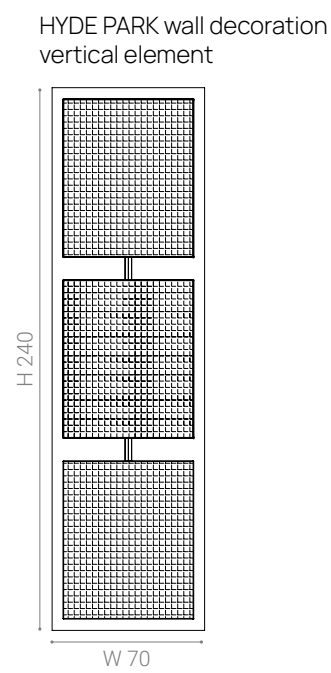

Plywood structure with metal details in smooth finishing. Available in eco-leather back panels with intreccio leather front panels.

Editorial story → P. 117
Materials & technical drawings → QR Code



SEGMENTI wall decoration
Bernhardt & Vella

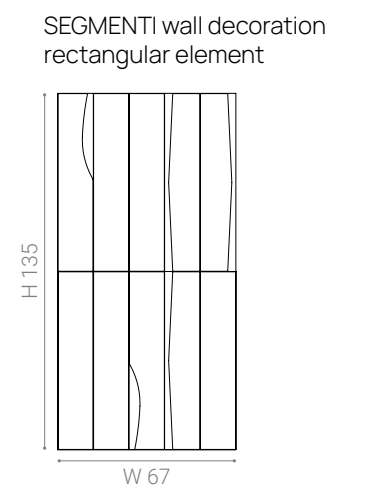
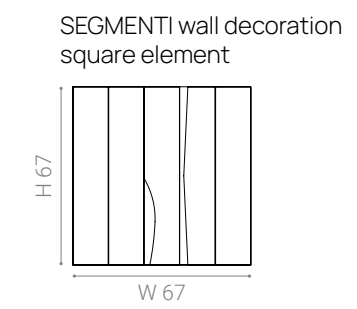

Plywood frame in smooth metallic finishing, with MDF lacquered front decorations.

Editorial story → P. 047
Materials & technical drawings → QR Code



NOMAD rug
Bernhardt & Vella



NOMAD rug rectangular

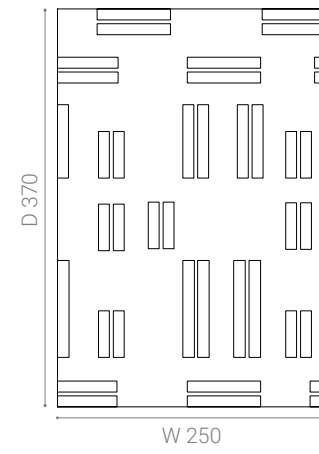

NOMAD rug oval

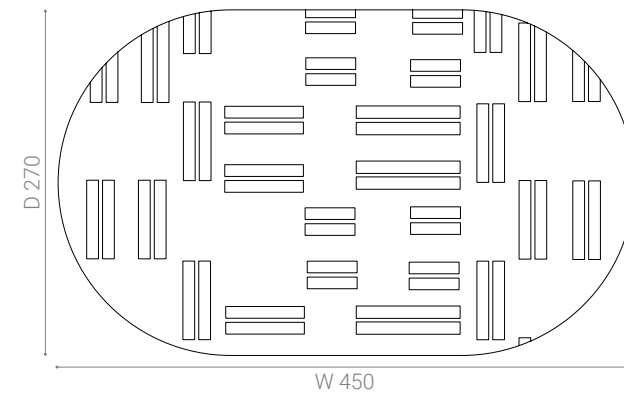

Hand tufted rug. 100% wool with nylon decorations. Available in charcoal grey color.

Editorial story → P.169
Materials & technical drawings → QR Code



TAMBOUR rug
Bernhardt & Vella

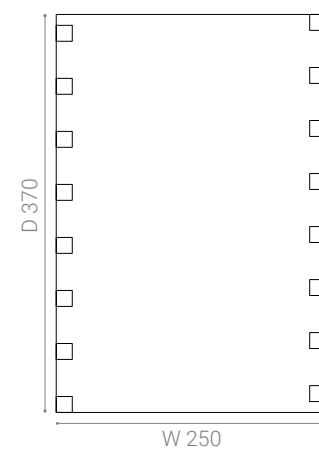

Hand tufted rug with metal inserts in metallic smooth finishing. 100% nylon. Available in grey color.

Editorial story → P.166
Materials & technical drawings → QR Code



MONOGRAPHY © 2024
Via Crosaron 23, 37053 Cerea, Verona
Tel. +39 0442 80594/80782/329256
contact@monography.it
@monography.sensualhome
monography.it

Photography by **Francesco Caredda, Stefan Giftthaler**
Graphic design by **MM Company**
Print by **Grafiche Antiga spa with vegetable inks on Fedrigoni recycled paper**
(Arena ECO50, Old Mill)

This catalogue respects the environment. The inks used are vegetable-based and the paper was produced using wood from forests managed to strict environmental standards: the companies involved guarantee sustainable eco-certified production.

Thank you to **Villa Badoer, Condominio San Luca - "Ex Palazzo INA" Verona**

